

Gunn's Hill Wind Farm **2019 Post-Construction Mortality** **Monitoring Report**

Prepared for:
GHLP General Partner Inc.
c/o Prowind Inc.
12 James Street North, Suite 202
Hamilton, ON
L8R 2J9

Project No. 1875C | February 2020



NATURAL RESOURCE SOLUTIONS INC.

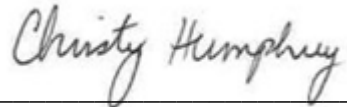
Aquatic, Terrestrial and Wetland Biologists

Gunn's Hill Wind Farm
2019 Post-construction Mortality Monitoring Report

Project Team:

Staff	Role
Christy Humphrey	Project Advisor/Biologist
Shelby Hofstetter	Project Manager/Biologist
Emily Kubesheskie	Biologist
Taylor Vance	Biologist
Kaitlin Filippov	GIS Technician

Report submitted on February 10, 2020



Christy Humphrey
Terrestrial and Wetland Biologist

Executive Summary

Natural Resource Solutions Inc. was retained to conduct 3 years of post-construction monitoring at the operational Gunn's Hill Wind Farm, located within the Township of Norwich, Oxford County, Ontario. This wind energy project has a generating capacity of 18MW and consists of 10 turbines situated in an agricultural landscape dominated by row crops. Occasional wooded habitats, wetlands, and aquatic features are also present in the areas surrounding the project infrastructure. This report provides the detailed methods and results from the third year of post-construction monitoring for bird and bat mortality conducted at the Gunn's Hill Wind Farm in 2019.

During twice-weekly searches from May 1 to October 31, 2019, a total of 10 bird mortalities were documented within the search areas around the 10 turbines. Observed bird mortalities consisted entirely of landbird species which are considered common in the province. Using appropriate correction factors, an estimated bird mortality rate of 1.73 birds/turbine/year (0.96 birds/MW/year), as calculated by turbine group, was determined for the Gunn's Hill Wind Farm. This is below the provincial threshold of 14 birds/turbine/year at turbine groups. No significant bird mortality events were documented.

During twice-weekly searches from May 1 to October 31, 2019, and once-weekly searches in November 2019, no raptor mortalities were documented within the search areas around the turbines. This resulted in an estimated raptor mortality rate of 0.00 raptors/turbine/year (0.00 raptors/MW/year). This is below the provincial threshold of 0.20 raptors/turbine/year.

During twice-weekly searches from May 1 to October 31, 2019, a total of 27 bat mortalities were documented within the search areas around the 10 turbines. Bat mortalities of both long-distance migratory and resident species were documented, including mortalities of Hoary Bat (*Lasiurus cinereus*), Silver-haired Bat (*Lasionycteris noctivagans*), Eastern Red Bat (*Lasiurus borealis*), and Big Brown Bat (*Eptesicus fuscus*). The first 3 species listed above are considered long-distance migratory species which over-winter outside of Ontario, and combined to account for 89% of the total bat mortality observations at the Gunn's Hill Wind Farm in 2019. Using appropriate correction factors, an estimated bat mortality rate of 5.94 bats/turbine/year (3.29 bats/MW/year) was determined for the Gunn's Hill Wind Farm. This is below the provincial threshold of 10 bats/turbine/year.

TABLE OF CONTENTS

1.0	Introduction	1
2.0	Mortality Monitoring Methodology	2
2.1	Mortality Monitoring	2
2.1.1	Sample Locations	2
2.1.2	Monitoring Period and Search Frequency	2
2.1.3	Sample Area and Survey Duration	2
2.1.4	Data Collection	3
2.2	Scavenger Removal Trials	3
2.3	Searcher Efficiency Trials	4
2.4	Proportion of Area Searched	5
3.0	Scavenger Removal Trial Results	7
4.0	Searcher Efficiency Trial Results	9
5.0	Proportion of Area Searched	11
6.0	Avian Mortality Results	12
6.1	Avian Mortalities	12
6.2	Temporal Distribution of Avian Mortalities	12
6.3	Spatial Distribution of Avian Mortalities	13
6.4	Corrected (Estimated) Avian Mortality	14
6.5	Summary	15
7.0	Raptor Mortality Results	16
7.1	Raptor Mortalities	16
7.2	Corrected (Estimated) Raptor Mortality	16
8.0	Bat Mortality Results	17
8.1	Bat Mortalities	17
8.2	Temporal Distribution of Bat Mortalities	17
8.3	Spatial Distribution of Bat Mortalities	18
8.4	Corrected (Estimated) Bat Mortality	19
8.5	Summary	20
9.0	Comparative Annual Results	22
9.1	Avian Mortality Results	22
9.2	Raptor Mortality Results	22
9.3	Bat Mortality Results	22
9.4	Summary	23
10.0	Mortality Thresholds and Notifications	24
10.1	Annual Bird Mortality	24
10.2	Annual Raptor Mortality	24
10.3	Annual Bat Mortality	24
10.4	Significant Bird Mortality Event	24
10.5	Species at Risk Mortality Event	25
11.0	Summary and Conclusions	26
12.0	References	28

List of Tables

Table 1. Summary of Regular Search Days When Turbines Could Not be Searched (2019).....	2
Table 2. Number of Carcasses Remaining During Scavenger Removal Trials at the Gunn's Hill WF (2019).....	7
Table 3. Results of Searcher Efficiency Trials at the Gunn's Hill WF (2019).....	9
Table 4. Proportion of Area Searched at the Gunn's Hill WF (2019).....	11
Table 5. Corrected Bird Mortality Rates Based on Mortality Monitoring at the Gunn's Hill WF (2019).....	15
Table 6. Corrected Bat Mortality Rates Based on Mortality Monitoring at the Gunn's Hill WF (2019).....	20
Table 7. Comparative Results of Avian Mortality Monitoring Seasons (2017-2019).....	22
Table 8. Comparative Results of Raptor Mortality Monitoring Seasons (2017-2019).....	22
Table 9. Comparative Results of Bat Mortality Monitoring Seasons (2017-2019).....	23

List of Figures

Figure 1. Bird Mortalities Observed by Month at the Gunn's Hill WF (2019).....	13
Figure 2. Bird Mortalities Observed by Turbine at the Gunn's Hill WF (2019).....	13
Figure 3. Bat Mortalities Observed by Date at the Gunn's Hill WF (2019).....	Error!
Bookmark not defined.	
Figure 4. Bat Mortalities Observed by Turbine at the Gunn's Hill WF (2019).....	18
Figure 5. Bat Mortalities Observed by Distance from Turbine at the Gunn's Hill WF (2019).....	19

List of Maps

Map 1	Mortality Monitoring Locations
-------	--------------------------------

List of Appendices

Appendix I	Post-construction Monitoring Data Sheets
Appendix II	Scavenger Removal Trial Results
Appendix III	Searcher Efficiency Trial Results
Appendix IV	Avian Mortalities
Appendix V	Bat Mortalities
Appendix VI	Locations of Bird and Bat Mortalities
Appendix VII	Visibility Class Mapping

1.0 Introduction

Natural Resource Solutions Inc. (NRSI) was retained to conduct the third year of post-construction monitoring at the operational Gunn's Hill Wind Farm (Gunn's Hill WF), which is located within the Township of Norwich, Ontario. The Gunn's Hill WF consists of 10 operational wind energy generating turbines with a total nameplate capacity of 18MW. The project area and turbine locations can be seen on Map 1.

Post-construction monitoring at the Gunn's Hill WF in 2019 included bird, bat, and raptor mortality monitoring, searcher efficiency trials, scavenger removal trials, and visibility class mapping of substrates searched. These surveys were conducted in accordance with provincial guidelines and approval conditions of the project to assess the potential impacts of this wind energy generating facility on birds and bats.

The purpose of this report is to provide the detailed methods and results from the third year of post-construction mortality monitoring conducted at the Gunn's Hill WF. It also reflects the first year of effectiveness monitoring, specific to bats, as a result of the Gunn's Hill WF previously exceeding the provincial threshold of 10 bats/turbine/year.

For the purposes of this report, NRSI will frequently use the terms 'mortality' and 'carcass'. The term 'mortality' will refer to dead birds and bats that were found in the vicinity of turbines at the Gunn's Hill WF. The term 'carcass' will refer to dead birds and bats that have been placed beneath wind turbines by NRSI staff for the purposes of searcher efficiency and/or scavenger removal trials.

In addition, an environmental monitor from Haudenosaunee Development Institute (HDI) was retained by Prowind Inc. One HDI environmental monitor accompanied the NRSI biologist during each monitoring survey and assisted with the searches from May to September, and as a result, in each case they are referred to herein as a "search team", where applicable.

2.0 Mortality Monitoring Methodology

2.1 Mortality Monitoring

2.1.1 Sample Locations

For wind energy projects consisting of fewer than 10 turbines, all turbines are required to be monitored (OMNR 2011a, OMNR 2011b). In accordance with these requirements, mortality monitoring was conducted at all 10 turbines in 2019, following the monitoring period and search frequency described below.

2.1.2 Monitoring Period and Search Frequency

The search team conducted twice-weekly (3 and 4 day intervals) mortality monitoring at each of the 10 turbines during the entire monitoring period of May 1 to October 31, 2019. Raptor mortality monitoring was conducted by NRSI biologists once-weekly at all turbines throughout the month of November.

As a result of turbine maintenance, some turbines could not be searched on the regularly scheduled date. These relatively minor adjustments to the monitoring protocol are not expected to impact the results or conclusions presented in this report. The dates when turbines were not able to be searched are listed below in Table 1.

Table 1. Summary of Regular Search Days When Turbines Could Not be Searched (2019)

Date (2019)	Date Turbine Next Searched (2019) ¹	Turbine(s)	Rationale
May 14	May 17 ¹	T01	Turbine Maintenance
October 22	October 25 ¹	T04	Turbine Maintenance
October 25	October 29 ¹	T07	Turbine Maintenance

¹ Due to a variety of factors which may include the duration of turbine maintenance, weather conditions, the location of the project, and/or staff restrictions, this turbine could not be searched again until the next regularly scheduled search day.

2.1.3 Sample Area and Survey Duration

Mortality searches were conducted within a 50m radius of each turbine base, using circular transects of increasing diameter around the turbine base, spaced approximately 5m apart. In order to maintain a consistent search effort, mortality searches followed a consistent search time of 20 minutes per turbine throughout the monitoring season. As teams consisting of 2 searchers conducted each of the surveys from May 1 to

September 30, this search time is equivalent to 40 minutes per turbine of total person-effort during these months.

During the month of October, the HDI monitor accompanied an NRSI searcher on only a few occasions. As a result, during the month of October the HDI monitor acted as an observer and followed behind the NRSI searcher and was asked not to point out any observed mortalities that may have been missed by the primary searcher. This ensured a consistent search effort throughout October of 20 minutes of total person effort per turbine.

2.1.4 Data Collection

During each visit to conduct mortality searches, all appropriate information was documented, including weather conditions, date, time, and observers. The mortality monitoring data sheet has been provided in Appendix I.

In addition to general information collected on each visit, a variety of specific information was recorded upon encountering any mortality. This detailed information, as shown on the data sheet provided in Appendix I, included species (if identifiable), sex, condition code, estimated time since death, any apparent injuries, direction and distance from turbine base, substrate type and visibility class, and a unique mortality identification number for future reference. Specific UTM coordinates and photographs were also taken for each specimen to allow for further analysis, if necessary.

2.2 Scavenger Removal Trials

Scavenger removal trials were conducted in each of the spring, summer, and fall seasons of mortality monitoring. For the purposes of this monitoring program, the spring monitoring season is defined as the months of May and June, the summer monitoring season is July and August, and the fall season is September and October. A minimum of 10 carcasses were placed in each monitoring season. No more than 5 carcasses were placed at one time and no more than 2 carcasses were placed at any single turbine during each placement event. These measures were taken to avoid bias in the trial resulting from saturation of carcasses available to scavengers. Carcasses were placed throughout the range of habitats and substrate types being searched during each season. Species, UTM coordinates, direction and distance from turbine base, substrate

and visibility class were all noted on a data sheet during the placement of each specimen. The scavenger removal data sheet has been provided in Appendix I.

Carcasses placed included both bird and bat specimens, with each trial consisting of at least one-third representation of each of bird and bat carcasses. Bird carcasses included species commonly encountered in this region of the province and ranged in size from very small to moderately-sized carcasses. Long-distance migratory bat carcasses were used in each seasonal scavenger removal trial and included Hoary Bat (*Lasiurus cinereus*), Eastern Red Bat (*Lasiurus borealis*), and Silver-haired Bat (*Lasionycteris noctivagans*). Carcasses used in scavenger removal trials were obtained from the Royal Ontario Museum and/or were collected from operational wind energy facilities within Ontario. A list of all of the bird and bat species used during scavenger removal trials has been provided in Appendix II.

During each scavenger removal trial, the bird and bat carcasses were left for up to 14 days and were checked at the same frequency as mortality searches, or approximately twice per week, to note any scavenging or signs of scavenger presence. Following the completion of the scavenger removal trials after 14 days, all remaining test carcasses were retrieved and disposed of appropriately.

2.3 Searcher Efficiency Trials

In conjunction with mortality searches, NRSI conducted searcher efficiency trials on searchers, or search teams, that conducted mortality searches at the Gunn's Hill WF. Similar to scavenger removal trials, searcher efficiency trials must be conducted at least once per season, as well as on each searcher/search team and in each visibility class that was searched during that season. In order to obtain more accurate results and to account for seasonal changes in groundcover, weather, or soil saturation, NRSI conducted monthly searcher efficiency trials from May to October. During each trial, searchers/search teams were tested without their knowledge through the placement of a minimum of 10 test carcasses per visibility class searched (class 1) with no more than 3 carcasses placed on any one date. Carcasses were placed randomly within the search radius of each of the 10 turbines at the Gunn's Hill WF. Distance and direction from turbine base, visibility class and substrate type, and UTM coordinates were recorded for each test carcass placed. Each found specimen was later compared to the total number

of carcasses placed within the project area, the locations of their placement. The data sheet used for searcher efficiency trials can be seen in Appendix I.

In order to meet the understood intent of the MNRF guidelines (OMNR 2011a, OMNR 2011b) to limit searcher bias, NRSI has not physically marked carcasses at this project, as it could influence the results of the trial and alert the searcher/search team to an ongoing searcher efficiency trial. Instead, NRSI biologists collect detailed location information of the trial carcass with UTM coordinates, distance and direction from the turbine, and mapped location of the carcass. All collected carcasses are compared to these detailed location and species information to distinguish between trial carcasses and actual turbine mortalities. These steps have been taken to ensure that the location of the carcass, along with species information, is well documented for future reference if there is uncertainty about whether or not an observed carcass is a turbine-related fatality or a trial carcass.

Searcher efficiency carcasses included both bird and bat specimens, with each trial consisting of at least one-third representation of each of bird and bat carcasses. In one month (June) the searcher efficiency trial consisted of 30% bat carcasses, instead of the one-third (i.e. 33%) requirement. This very minor deviation is not expected to have any material result on the annual corrected mortality rate for birds, raptors, or bats. Bird carcasses included species commonly encountered in this region of the province and varied in size from very small to moderate-sized carcasses. Bat carcasses used during searcher efficiency trials consisted of the 3 long-distance migratory species known to occur within Ontario, including Hoary Bat, Eastern Red Bat, and Silver-haired Bat. Carcasses used in searcher efficiency trials were obtained from the Royal Ontario Museum and/or were collected from operational wind energy facilities within Ontario. A list of all of the bird and bat species used during searcher efficiency trials has been provided in Appendix III.

2.4 Proportion of Area Searched

Following Ministry of Natural Resources and Forestry (MNRF) guidelines, visibility class maps were completed by searchers at a minimum frequency of once per season (OMNR 2011a, OMNR 2011b). Due to the potential for changing conditions, NRSI completed visibility class maps once per month from May to October to provide additional

information to support whether more frequent searcher efficiency trials were warranted, and ultimately to increase the accuracy of the estimated mortality rates.

Visibility class mapping was completed for the full 50m search radius at each turbine. This mapping categorized habitats according to visibility classes recommended by the MNRF (OMNR 2011a, OMNR 2011b). These include visibility classes 1 through 4, in addition to areas which may be deemed “unsearchable”, such as wooded areas, areas deemed safety hazards, or other areas where searching was not possible. Mapping of these visibility classes within each turbine’s search radius was conducted and calculated as per a repeatable methodology using a combination of these visibility class field maps, review of aerial photographs, and Geographic Information System (GIS) software. The data sheet used to record visibility class mapping has been provided in Appendix I.

In order to help increase the accuracy of searcher efficiency rates and minimize the influence of the proportion of area searched on the bird and bat mortality estimates, the 50m search radii at each of the 10 turbines were maintained at visibility class 1 through occasional plowing for the duration of the monitoring year (May through November), when necessary. When small and temporary areas of other visibility classes were present, they were searched thoroughly until scheduled vegetation maintenance could occur. As a result, the majority of the 50m radius at each turbine was searched for the duration of the 2019 monitoring period. Some areas were determined to be visibility classes that were not searched as part of this monitoring program (i.e. visibility classes 2-4). In these cases, the appropriate proportion of area searched was calculated and used for final mortality estimates. Visibility class maps of each turbine in each month are provided in Appendix VII.

Maintenance of the 50m search radius was only completed when necessary to maintain appropriate visibility and it also followed a strict schedule developed by NRSI that ensured the maintenance activities were completed in a manner to minimize or eliminate any potential negative influence on the mortality monitoring, searcher efficiency trials, and scavenger removal trials. The maintenance of the search areas is expected to increase the accuracy of the final estimated mortality rates at the Gunn’s Hill WF.

3.0 Scavenger Removal Trial Results

Scavenging activity at the Gunn's Hill WF was low to moderate throughout the monitoring seasons, with the lowest amount of scavenging activity documented during the spring trial. Table 2 shows the results from each season's scavenger removal trials conducted at the Gunn's Hill WF. Details on the date placed, species, distance and direction from turbine, visibility class, dates checked and by whom, UTM coordinates, and whether the carcass was scavenged have been provided in Appendix II.

Table 2. Number of Carcasses Remaining During Scavenger Removal Trials at the Gunn's Hill WF (2019)

Number of Carcasses Remaining					
Spring Trial (May/June)					
Turbine	Visit 0	Visit 1	Visit 2	Visit 3	Visit 4
T02	1	1	1	1	1
T03	2	2	2	1	1
T04	1	1	1	1	1
T05	1	1	1	1	1
T06	1	1	1	1	0
T07	1	0	0	0	0
T08	1	1	1	1	1
T09	1	0	0	0	0
T10	1	1	1	1	1
Total	10	8	8	7	6
Summer Trial (July/August)					
Turbine	Visit 0	Visit 1	Visit 2	Visit 3	Visit 4
T01	1	0	0	0	0
T02	1	1	1	0	0
T03	1	0	0	0	0
T04	1	1	1	1	1
T05	1	1	0	0	0
T06	1	0	0	0	0
T07	1	0	0	0	0
T08	1	0	0	0	0
T09	1	0	0	0	0
T10	1	1	1	1	1
Total	10	4	3	2	2
Fall Trial (September/October)					
Turbine	Visit 0	Visit 1	Visit 2	Visit 3	Visit 4
T01	1	1	1	0	0
T02	1	0	0	0	0
T03	1	1	1	0	0

Number of Carcasses Remaining					
T04	1	1	1	1	1
T05	1	1	1	0	0
T06	1	1	0	0	0
T07	1	1	1	1	0
T08	1	0	0	0	0
T09	1	1	0	0	0
T10	1	0	0	0	0
Total	10	7	5	2	1

To address the scavenger removal rates for each of the specific monitoring periods, NRSI has used the equation recommended by the MNRF:

$$Sc = \frac{n_{\text{visit1}} + n_{\text{visit2}} + n_{\text{visit3...}}}{n_{\text{visit0}} + n_{\text{visit1}} + n_{\text{visit2...}}}$$

Sc: proportion of carcasses not removed by scavengers

n_{visit0} : total number of carcasses placed

$n_{\text{visit1}} - n_{\text{visit3...}}$: numbers of carcasses remaining on visits 1 through 3 etc.

Using the scavenger removal results seen in Table 2 and the equation provided by the MNRF, the seasonal scavenger removal rates have been determined as follows:

$$\begin{aligned} Sc_{\text{Spring}} &= (8 + 8 + 7 + 6) / (10 + 8 + 8 + 7) \\ &= 29 / 33 \\ &= \mathbf{0.88} \end{aligned}$$

$$\begin{aligned} Sc_{\text{Summer}} &= (4 + 3 + 2 + 2) / (10 + 4 + 3 + 2) \\ &= 11 / 19 \\ &= \mathbf{0.58} \end{aligned}$$

$$\begin{aligned} Sc_{\text{Fall}} &= (7 + 5 + 2 + 1) / (10 + 7 + 5 + 2) \\ &= 15 / 24 \\ &= \mathbf{0.63} \end{aligned}$$

The above scavenger removal rates represent the proportion of carcasses still remaining from one visit to the next. These scavenger values generally represent low to moderate scavenging activity throughout the year. The above scavenger removal rates will be used to calculate the estimated avian and bat mortality rates in Sections 6.0 and 8.0.

4.0 Searcher Efficiency Trial Results

Searcher efficiency rates at the Gunn's Hill WF were relatively high throughout the 2019 monitoring season. Results of the monthly searcher efficiency trials are summarized in Table 3 below. Details on the searcher, species, distance and direction from turbine, habitat, substrate, visibility class, UTM coordinates, and whether the carcass was found or scavenged have been provided in Appendix III.

Table 3. Results of Searcher Efficiency Trials at the Gunn's Hill WF (2019)

Searcher	Carcasses Found	Carcasses Placed	Carcasses Scavenged	Searcher Efficiency (Se)	Proportion of Turbines Searched
May 2019					
Search Team A	9	10	0	0.90	1.00
June 2019					
Search Team A	9	10	0	0.90	0.75
Search Team B ¹	N/A	N/A	N/A	0.90	0.25
July 2019					
Search Team C	8	10	0	0.80	1.00
August 2019					
Search Team C	7	11	1	0.70	1.00
September 2019					
Search Team C	8	10	0	0.80	1.00
October 2019					
Searcher A	9	10	0	0.90	1.00

¹This search team searched on no more than 2 days in the identified month and therefore could not be properly tested for searcher efficiency following MNRF guidelines (i.e. 4 search days are required for proper testing in 1 visibility class as no more than 3 carcasses can be placed at a time). In these circumstances, the average result obtained by the regular search team in each month was used for this search team.

Based on the information collected during detailed searcher efficiency trials and equations recommended by the MNRF, searcher efficiency (SeO) was calculated for each of the monitoring months as follows:

$$Se = \frac{\text{number of test carcasses found}}{\text{number of test carcasses placed} - \text{number of test carcasses scavenged}}$$

$$SeO = Se_A(\text{proportion of turbines searched}) + Se_B(\text{proportion of turbines searched})...$$

$$\begin{aligned}
 SeO_{\text{May}} &= 0.90 (1.00) = \mathbf{0.90} \\
 SeO_{\text{June}} &= 0.90 (0.75) + 0.90 (0.25) = \mathbf{0.90} \\
 SeO_{\text{July}} &= 0.80 (1.00) = \mathbf{0.80} \\
 SeO_{\text{August}} &= 0.70 (1.00) = \mathbf{0.70} \\
 SeO_{\text{September}} &= 0.80 (1.00) = \mathbf{0.80} \\
 SeO_{\text{October}} &= 0.90 (1.00) = \mathbf{0.90}
 \end{aligned}$$

These searcher efficiency values represent relatively high searcher efficiency rates, largely due to the steps taken to keep the search areas in low visibility classes (i.e. clear and more easily searched) to increase the accuracy of the estimated mortality rate. These values will be used to calculate the estimated avian and bat mortality rates in Sections 6.0 and 8.0.

5.0 Proportion of Area Searched

Visibility class mapping was completed every month within the 50m search radius of each of the 10 turbines in order to reflect changes in groundcover and resulting visibility classes. All visibility class maps have been provided in Appendix VII.

Visibility class mapping was used in combination with GIS software to determine the proportion of area in visibility class 1 at each turbine. During the 2019 monitoring program, NRSI biologist searched all areas of visibility class 1, which is reflected in the proportion of area searched (P_s) calculated for all 10 turbines during each monitoring month, as shown in Table 4. The P_s values will be used to calculate the estimated avian, raptor, and bat mortality rates in Sections 6.0, 7.0, and 8.0 respectively.

Table 4. Proportion of Area Searched at the Gunn's Hill WF (2019)

Month	Total Searched Area (m ²)	Total Search Radius (m ²)	Proportion of Area Searched (P_s)
May	77,794	78,500	0.99
June	77,794	78,500	0.99
July	75,083	78,500	0.96
August	74,754	78,500	0.95
September	74,500	78,500	0.95
October	71,435	78,500	0.91

6.0 Avian Mortality Results

6.1 Avian Mortalities

During the 2019 mortality monitoring period at the Gunn's Hill WF, searchers found 10 bird mortalities within the 50m search radius of the turbines. In addition, one Chukar (*Alectoris chukar*) mortality was found, at turbine T08. There are no self-sustaining populations of this species in the wild in Ontario as per the Ontario Field Ornithologists (OFO 2019) and the Natural Heritage Information Centre (MNRF 2018), and therefore this observed mortality likely represents an escape from a game farm or a release for hunting. As such, this game bird has not been included in the various results discussion and calculation of estimated mortality rates that are found below.

The majority of the mortalities that could be identified to the species level were confirmed to be small landbirds that are common species for this area of the province. The most commonly observed mortalities were of Red-eyed Vireo (*Vireo olivaceus*) (n=3). Two bird mortalities could not be identified to the species level due to advanced decomposition, but were identified as a passerine species and a warbler species respectively.

A complete list of all avian mortalities observed during the mortality searches has been provided in Appendix IV.

6.2 Temporal Distribution of Avian Mortalities

Bird mortalities were observed during the spring, summer, and fall monitoring periods. Mortality was highest in the month of October, when 4 mortalities were observed. The distribution of avian mortalities by month is shown in Figure 1 below.

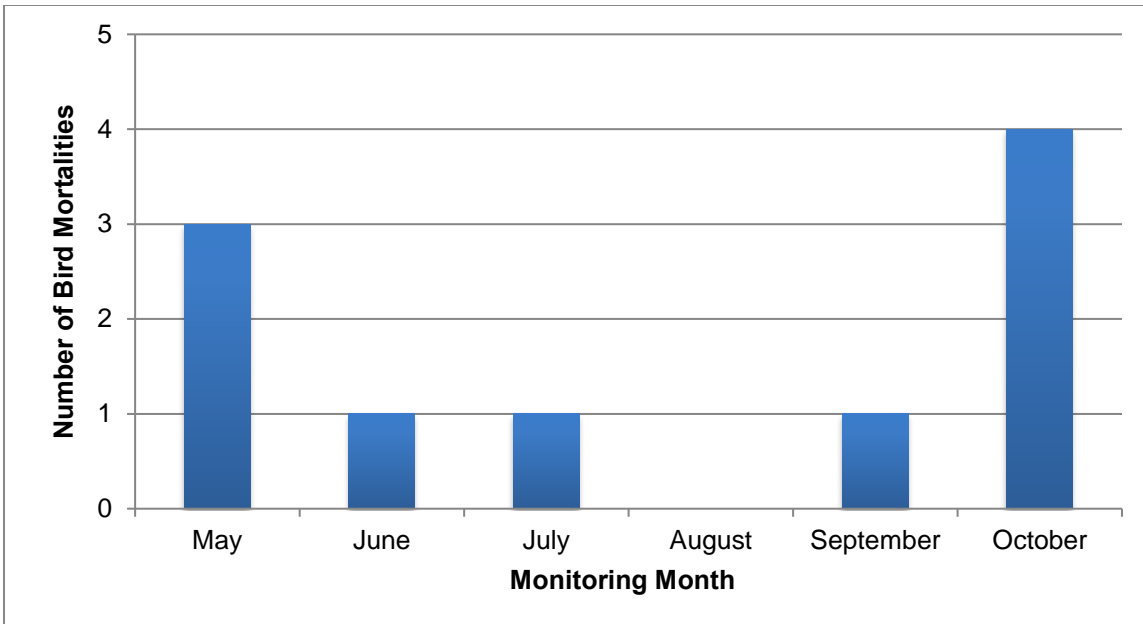


Figure 1. Bird Mortalities Observed by Month at the Gunn's Hill WF (2019)

6.3 Spatial Distribution of Avian Mortalities

Avian mortalities were observed at 6 of the 10 turbines (see Figure 2 below). The highest number of mortalities observed at a single turbine was 3, which occurred at turbines T09 and T10. Turbine maps identifying the location of each observed mortality have been provided in Appendix VI.

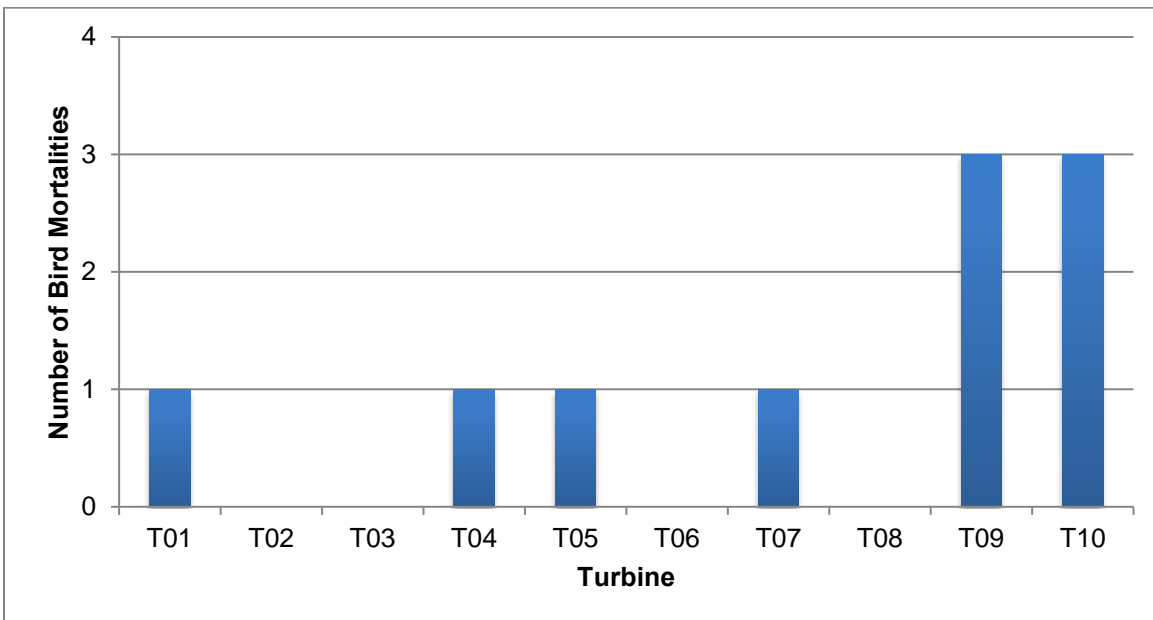


Figure 2. Bird Mortalities Observed by Turbine at the Gunn's Hill WF (2019)

6.4 Corrected (Estimated) Avian Mortality

In accordance with the *Bird and Bird Habitats: Guidelines for Wind Power Projects* (OMNR 2011b), estimated avian mortality rates have been presented by individual turbines or turbine group. Given the small size of the Gunn's Hill WF (10 turbines), the entire facility has been considered a single turbine group for the purpose of establishing estimated mortality rates.

Based on the field observations at the Gunn's Hill WF, NRSI biologists have compiled the searcher efficiency trial results, scavenger removal trial results, proportion of area searched, and direct mortality observations into an equation that will be used to estimate the total avian mortality at the Gunn's Hill WF in 2019. The equation recommended by the MNRF is found below:

$$C = c / (Se * Sc * Ps)$$

C: Corrected (Estimated) Mortality Rate
c: actual observed mortalities
Se: overall searcher efficiency
Sc: proportion of remaining carcasses
Ps: proportion of area searched

Using the equation and variables described above, the estimated avian mortality rates by month have been presented below:

$$\begin{aligned} C_{\text{May}} &= 3 / (0.90 * 0.88 * 0.99) = 3 / 0.7841 = 3.83 \text{ birds} \\ &= \mathbf{0.38 \text{ birds/turbine}} \text{ (0.21 birds/MW)} \\ C_{\text{June}} &= 1 / (0.90 * 0.88 * 0.99) = 1 / 0.7841 = 1.28 \text{ birds} \\ &= \mathbf{0.13 \text{ birds/turbine}} \text{ (0.07 birds/MW)} \\ C_{\text{July}} &= 1 / (0.80 * 0.58 * 0.96) = 1 / 0.4454 = 2.25 \text{ birds} \\ &= \mathbf{0.23 \text{ birds/turbine}} \text{ (0.13 birds/MW)} \\ C_{\text{August}} &= 0 / (0.70 * 0.58 * 0.95) = 0 / 0.3857 = 0.00 \text{ birds} \\ &= \mathbf{0.00 \text{ birds/turbine}} \text{ (0.00 birds/MW)} \\ C_{\text{September}} &= 1 / (0.80 * 0.63 * 0.95) = 1 / 0.4788 = 2.09 \text{ birds} \\ &= \mathbf{0.21 \text{ birds/turbine}} \text{ (0.12 birds/MW)} \\ C_{\text{October}} &= 4 / (0.90 * 0.63 * 0.91) = 4 / 0.5160 = 7.75 \text{ birds} \\ &= \mathbf{0.78 \text{ birds/turbine}} \text{ (0.43 birds/MW)} \end{aligned}$$

6.5 Summary

A total of 10 avian mortalities were documented at the Gunn's Hill WF in 2019. Avian mortalities were found at 6 out of 10 turbines, ranging from 0 to 3 mortalities per turbine. Mortalities were observed during the spring, summer, and fall monitoring seasons, with the highest number of mortalities occurring during the month of October.

Using the appropriate variables and equations recommended by the MNRF, the corrected (estimated) avian mortality at the Gunn's Hill WF in 2019 was calculated. Table 5 shows the monthly estimated mortality rates as well as the overall estimated avian mortality rate at the Gunn's Hill WF, as calculated by turbine group.

Table 5. Corrected Bird Mortality Rates Based on Mortality Monitoring at the Gunn's Hill WF (2019)

Month (2019)	Observed Avian Mortalities	Corrected Mortality (birds/turbine)	Corrected Mortality (birds/MW)
May	3	0.38	0.21
June	1	0.13	0.07
July	1	0.23	0.13
August	0	0.00	0.00
September	1	0.21	0.12
October	4	0.78	0.43
TOTAL	10	1.73	0.96

Based on the information collected during the 2019 post-construction monitoring period, the anticipated impact of this facility on birds is characterized by an estimated mortality rate of **1.73 birds/turbine/year** (0.96 birds/MW/year), as calculated by turbine group.

7.0 Raptor Mortality Results

7.1 Raptor Mortalities

Mortality searches for raptors were conducted twice-weekly from May to October in conjunction with avian and bat mortality searches and once-weekly in November at each of the 10 turbines. No raptor mortalities were documented during these searches at the Gunn's Hill WF in 2019.

7.2 Corrected (Estimated) Raptor Mortality

Based on the information collected during the 2019 post-construction monitoring period, the anticipated impact of this facility on raptors is characterized by an estimated mortality rate of **0.00 raptors/turbine/year**.

8.0 Bat Mortality Results

8.1 Bat Mortalities

During the 2019 post-construction mortality monitoring period at the Gunn's Hill WF, searchers observed 27 bat mortalities within the 50m search radius of the turbines. Bat mortalities represented 4 different species, including the 3 long-distance migratory species, Hoary Bat, Eastern Red Bat, and Silver-haired Bat, as well as the resident species Big Brown Bat (*Eptesicus fuscus*). The most abundant species observed was Hoary Bat (n=14), followed by Silver-haired Bat (n=9), Big Brown Bat (n=3), and Eastern Red Bat (n=1). Observed mortalities of the 3 long-distance migratory bat species combined to represent 89% of all documented bat mortalities.

A detailed examination of bat mortalities at the Gunn's Hill WF has been included in the following sections. Detailed information regarding each bat mortality observed during mortality searches has been provided in Appendix V.

8.2 Temporal Distribution of Bat Mortalities

Bat mortalities were observed throughout the monitoring period, but were most abundant during the months of July through September (81% of all bat mortalities; Figure 3). The monitoring day with the highest number of mortalities observed was September 3, 2019 (n=3).

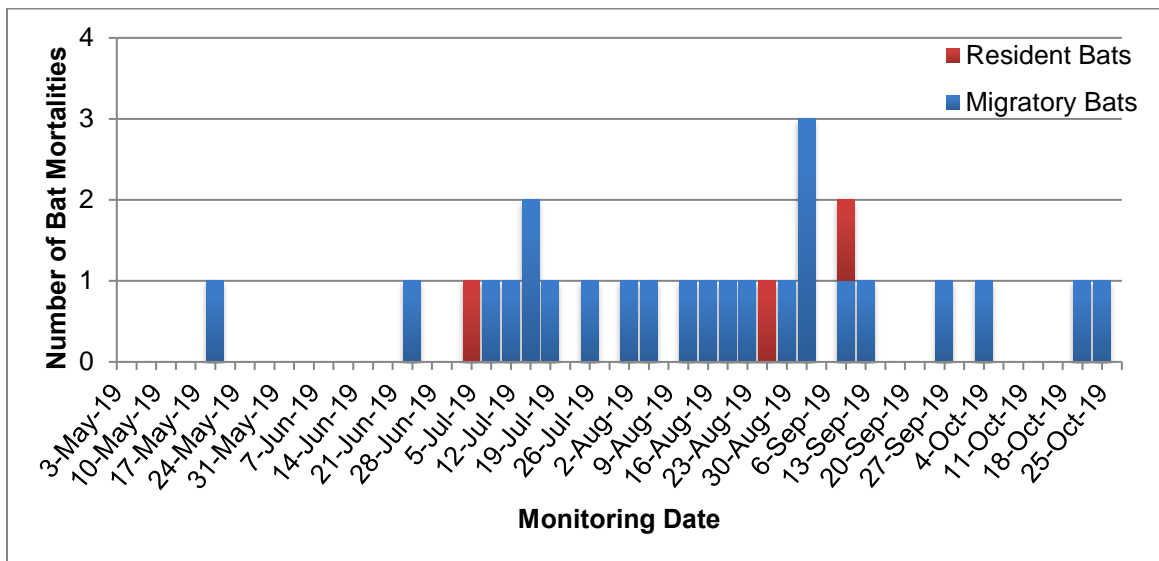


Figure 3. Bat Mortalities Observed by Date at the Gunn's Hill WF (2019)

Patterns of bat mortalities appear to be consistent with the expected migratory time periods for these species, with increases in bat mortalities during the mid-summer. Overall, bat mortality was concentrated during the months of July through September, corresponding to the anticipated peak periods of summer swarming and migration of bats.

8.3 Spatial Distribution of Bat Mortalities

Bat mortalities were observed at 9 of the 10 turbines at the Gunn's Hill WF in 2019 (see Figure 4 below). The number of mortalities observed at each turbine varied, ranging from 0 mortalities at turbine T08 to 6 mortalities at turbine T01.

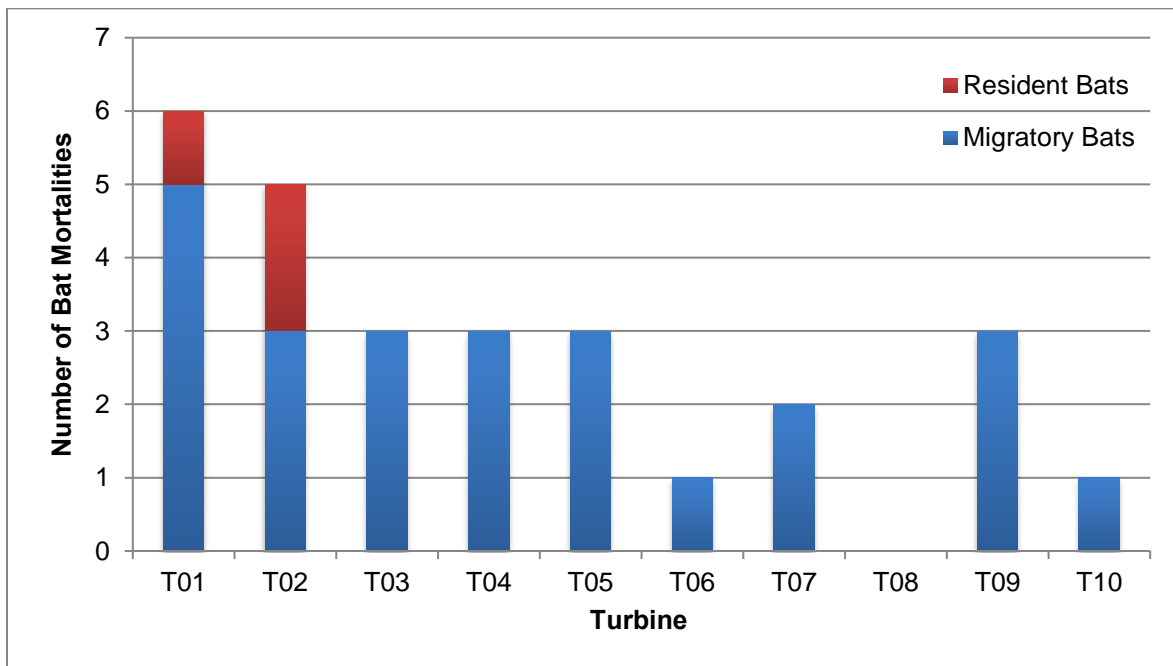


Figure 4. Bat Mortalities Observed by Turbine at the Gunn's Hill WF (2019)

Distance and direction of bat mortalities from each of the turbine bases were also documented for each observed mortality. Bat mortalities were found ranging in distance from 13m to 46m from the turbine base, and averaging a distance of approximately 31m from the turbine base. Bat mortalities were not documented closer than 13m from the turbine base. The overall distribution of mortalities by distance class can be seen in Figure 5 below. Maps identifying the location of each observed mortality by turbine are provided in Appendix VI.

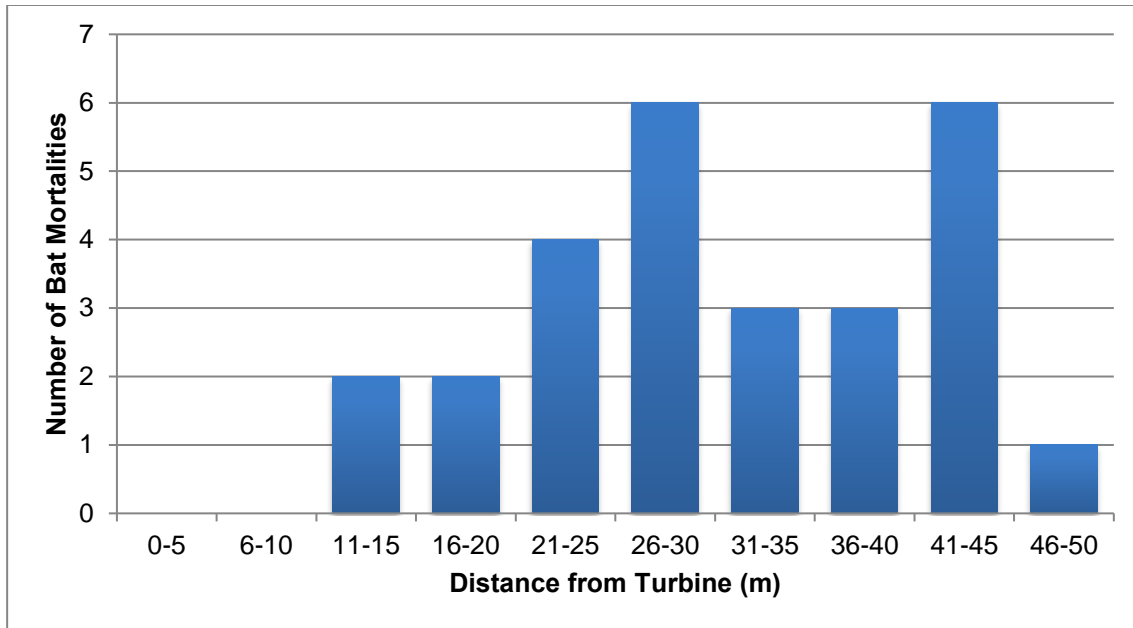


Figure 5. Bat Mortalities Observed by Distance from Turbine at the Gunn's Hill WF (2019)

8.4 Corrected (Estimated) Bat Mortality

Based on the field observations at the Gunn's Hill WF, NRSI biologists have compiled the searcher efficiency trials, scavenger removal trials, proportion of area searched, and direct mortality values in an equation that will be used to estimate the total bat mortality at the Gunn's Hill WF in 2019. The equation recommended by the MNRF is found below:

$$C = c / (Se * Sc * P_s)$$

- C: Corrected (Estimated) Mortality Rate
- c: actual observed mortalities
- Se: overall searcher efficiency
- Sc: proportion of remaining carcasses
- P_s: proportion of area searched

Using the equation and variables described above, the estimated bat mortality rates (by month) have been presented below:

$$C_{\text{May}} = 1 / (0.90 * 0.88 * 0.99) = 1 / 0.7841 = 1.28 \text{ bats}$$

$$= \mathbf{0.13 \text{ bats/turbine}} \text{ (0.07 bats/MW)}$$

$$C_{\text{June}} = 1 / (0.90 * 0.88 * 0.99) = 1 / 0.7841 = 1.28 \text{ bats}$$

$$= \mathbf{0.13 \text{ bats/turbine}} \text{ (0.07 bats/MW)}$$

$$C_{\text{July}} = 7 / (0.80 \cdot 0.58 \cdot 0.96) = 7 / 0.4454 = 15.72 \text{ bats}$$

$$= \mathbf{1.57 \text{ bats/turbine}} \text{ (0.87 bats/MW)}$$

$$C_{\text{August}} = 8 / (0.70 \cdot 0.58 \cdot 0.95) = 8 / 0.3857 = 20.74 \text{ bats}$$

$$= \mathbf{2.07 \text{ bats/turbine}} \text{ (1.15 bats/MW)}$$

$$C_{\text{September}} = 7 / (0.80 \cdot 0.63 \cdot 0.95) = 7 / 0.4788 = 14.62 \text{ bats}$$

$$= \mathbf{1.46 \text{ bats/turbine}} \text{ (0.81 bats/MW)}$$

$$C_{\text{October}} = 3 / (0.90 \cdot 0.63 \cdot 0.91) = 3 / 0.5160 = 5.81 \text{ bats}$$

$$= \mathbf{0.58 \text{ bats/turbine}} \text{ (0.32 bats/MW)}$$

8.5 Summary

A total of 27 bat mortalities were documented at the Gunn's Hill WF in 2019. Mortalities included 3 of Ontario's long-distance migratory bat species, Hoary Bat, Silver-haired Bat, and Eastern Red Bat which represented 89% of the total bat mortalities observed. Big Brown Bat, a resident species known to over-winter in Ontario, was also observed. Bat mortalities were most abundant during the months of July through September, when 81% of all bat mortalities occurred. Bat mortalities ranged from 0 to 6 mortalities at each turbine.

Using the appropriate variables and recommended equations provided by the MNRF, NRSI has determined the corrected (estimated) bat mortality at the Gunn's Hill WF in 2019. Each of the corrected monthly bat mortality rates and the corrected annual bat mortality rate for the Gunn's Hill WF are provided in Table 6.

Table 6. Corrected Bat Mortality Rates Based on Mortality Monitoring at the Gunn's Hill WF (2019)

Month (2019)	Observed Bat Mortalities	Corrected Mortality (bats/turbine)	Corrected Mortality (bats/MW)
May	1	0.13	0.07
June	1	0.13	0.07
July	7	1.57	0.87
August	8	2.07	1.15
September	7	1.46	0.81
October	3	0.58	0.32
TOTAL	27	5.94	3.29

Based on the information collected during the 2019 post-construction monitoring period, the anticipated impact of this facility on bats is characterized by a corrected mortality rate of **5.94 bats/turbine/year** (3.29 bats/MW/year).

9.0 Comparative Annual Results

Mortality monitoring conducted by NRSI in 2019 represents the third year of post-construction monitoring conducted at the Gunn's Hill WF. The following section provides a comparison of the 2017, 2018, and 2019 post-construction mortality monitoring results.

9.1 Avian Mortality Results

Table 7 below provides an abbreviated summary of total bird mortalities, monitoring periods, and corrected (estimated) mortality rates for each of the 3 years of mortality monitoring conducted to-date at the Gunn's Hill WF.

Table 7. Comparative Results of Avian Mortality Monitoring Seasons (2017-2019)

Year	Total Mortalities	Monitoring Period	Corrected Mortality Rates	
			Birds/Turbine/Year	Birds/MW/Year
2017	7	May 1 – October 31	1.03	0.57
2018	14	May 1 – October 31	2.96	1.63
2019	10	May 1 – October 31	1.73	0.96

Further details of the 2019 avian mortality results can be found in Section 6.0 of this report.

9.2 Raptor Mortality Results

Table 8 below provides an abbreviated summary of total raptor mortalities, monitoring periods, and corrected (estimated) mortality rates for each of the 3 years of mortality monitoring conducted to-date at the Gunn's Hill WF.

Table 8. Comparative Results of Raptor Mortality Monitoring Seasons (2017-2019)

Year	Total Mortalities	Monitoring Period	Corrected Mortality Rates	
			Raptors/Turbine/Year	Raptors/MW/Year
2017	1	May 1 – November 30	0.10	0.06
2018	4	May 1 – November 30	0.43	0.24
2019	0	May 1 – November 30	0.00	0.00

Further details of the 2019 raptor mortality results can be found in Section 7.0 of this report.

9.3 Bat Mortality Results

Table 9 below provides an abbreviated summary of total bat mortalities, monitoring periods, and corrected (estimated) mortality rates for each of the 3 years of mortality monitoring conducted to-date at the Gunn's Hill WF.

Table 9. Comparative Results of Bat Mortality Monitoring Seasons (2017-2019)

Year	Total Mortalities	Monitoring Period	Estimated Mortality Rates	
			Bats/Turbine/Year	Bats/MW/Year
2017	68	May 1 – October 31	10.81	5.99
2018	36	May 1 – October 31	9.05	5.02
2019	27	May 1 – October 31	5.94	3.29

Further details of the 2019 bat mortality results can be found in Section 8.0 of this report.

9.4 Summary

Although a general comparison between the 3 years of post-construction monitoring data is possible, the differences in searcher efficiency rates, scavenger removal rates, and proportion area searched over these 3 monitoring years do not necessarily allow for a direct comparative analysis of observed mortalities between the 3 years. Local bird and bat abundance and behaviour will also change annually based on other variables, such as weather conditions, adjacent land uses, food availability, or general variations in population numbers, further adding to the challenges of making direct comparisons between monitoring years.

Despite these comparative challenges, general comparisons between the monitoring years have been made. Overall, the number of avian mortalities has remained relatively consistent between the 3 monitoring years, but the number of raptor and bat mortalities decreased in 2019 relative to the 2017 and 2018 monitoring results.

10.0 Mortality Thresholds and Notifications

In accordance with the appropriate MNRF guidelines, project approval conditions, and other commitments made as part of the monitoring program, several mortality thresholds and notification requirements for the Gunn's Hill WF have been established. The status of each threshold and confirmation of notifications, where applicable, have been described in the following sections.

10.1 Annual Bird Mortality

The annual bird mortality threshold for the Gunn's Hill WF is 14 birds/turbine/year, calculated by individual turbine or turbine group. Based on an estimated rate of 1.73 birds/turbine/year, as calculated by turbine group, the Gunn's Hill WF remains below this threshold. Since the results are below the established threshold, no notification is required.

10.2 Annual Raptor Mortality

The annual raptor mortality threshold for the Gunn's Hill WF is 0.2 raptors/turbine/year, or 0.1 raptors/turbine/year for provincially tracked raptors. Based on an estimated rate of 0.00 raptors/turbine/year and no mortalities of provincially tracked raptors, the Gunn's Hill WF remains below these thresholds. Since the results are below the established thresholds, no notifications are required.

10.3 Annual Bat Mortality

The annual bat mortality threshold for the Gunn's Hill WF is 10 bats/turbine/year. Based on an estimated rate of 5.94 bats/turbine/year, the Gunn's Hill WF remains below this threshold. Since the results are below the established threshold, no notification is required.

10.4 Significant Bird Mortality Event

Significant bird mortality events have been defined by the MNRF as single-day mortality events with 10 or more birds at any one turbine or 33 or more birds (including raptors) at multiple turbines. Neither of these single-day mortality events was observed at the Gunn's Hill WF during the 2019 monitoring year. As no significant bird mortality event occurred, no notification is required.

10.5 Species at Risk Mortality Event

Any Species at Risk (SAR; MECP 2019) mortality documented during post-construction mortality monitoring at the Gunn's Hill WF requires formal notification to the MNRF within 24 hours (or next business day) of a confirmed species identification (Prowind Canada Inc. 2013). No provincially-listed SAR bird or bat mortalities were documented by NRSI at the Gunn's Hill Wind Farm during post-construction mortality monitoring in 2019.

11.0 Summary and Conclusions

NRSI was retained to conduct post-construction monitoring at the operational Gunn's Hill WF. The Gunn's Hill WF consists of 10 operational wind energy generating turbines with a total nameplate capacity of 18MW.

Post-construction monitoring at the Gunn's Hill WF in 2019 included bird, bat, and raptor mortality monitoring, searcher efficiency trials, scavenger removal trials, and visibility class mapping. These surveys were conducted to assess the potential impacts of this wind energy generating facility on local and migratory birds and bats. Monitoring in 2019 also represents the first year of effectiveness monitoring, specific to bats, which is required as a result of exceeding the provincial threshold during a previous monitoring year.

A total of 10 avian mortalities were documented at the Gunn's Hill WF during the 2019 monitoring period. Given the number of observed avian mortalities, searcher efficiency rates, scavenger removal rates, proportion of area searched, and equations recommended by the MNRF, a total corrected (estimated) avian mortality rate of **1.73 birds/turbine/year** (0.96 birds/MW/year), as calculated by turbine group, has been determined for the Gunn's Hill WF. This estimated mortality rate is below the threshold level of 14 birds/turbine/year established by the MNRF guidelines. No significant bird mortality events of 10 or more birds at any one turbine or 33 or more birds (including raptors) at multiple turbines on a single survey date were observed.

No raptor mortalities were documented at the Gunn's Hill WF during the 2019 monitoring period. Based on the absence of raptor mortalities, a raptor mortality rate of **0.00 raptors/turbine/year** (0.00 raptors/MW/year) has been determined for the Gunn's Hill WF. This raptor mortality rate is below the established provincial threshold level of 0.2 raptors/turbine/year.

A total of 27 bat mortalities were documented during the 2019 mortality monitoring period at the Gunn's Hill WF. Long-distance migratory bat species were the most commonly observed mortalities at the project. Based on the number of observed bat mortalities, searcher efficiency rates, scavenger removal rates, proportion of area

searched, and equations recommended by the MNRF, a total corrected (estimated) bat mortality rate of **5.94 bats/turbine/year** (3.29 bats/MW/year) has been determined for the Gunn's Hill WF. The estimated bat mortality rate is below the provincial threshold level of 10 bats/turbine/year established by the MNRF guidelines.

12.0 References

- Ministry of Environment, Conservation and Parks (MECP). 2019. Species at Risk in Ontario (SARO). Available at: <https://www.ontario.ca/page/species-risk-ontario>
- Ministry of Natural Resources and Forestry (MNR). 2018. Species Lists: Birds. Natural Heritage Information Centre (NHIC). Queen's Printer for Ontario. Available at: <https://www.ontario.ca/page/get-natural-heritage-information>
- Ontario Field Ornithologists (OFO). 2019. Checklist of the Birds of Ontario. Available at: <http://www.ofo.ca/checklist/checklist>
- Ontario Ministry of Natural Resources (OMNR). 2011a. Bats and Bat Habitats: Guidelines for Wind Power Projects. First edition. July 2011.
- Ontario Ministry of Natural Resources (OMNR). 2011b. Bird and Bird Habitats: Guidelines for Wind Power Projects. First Edition. December 2011.
- Prowind Canada Inc. 2013. Gunn's Hill Wind Farm - Post-construction Environmental Effects Monitoring Plan: Birds and Bats. June 2013.

Maps

Appendix I
Post-construction Monitoring Data Sheets

Searcher Efficiency Data Form

Project Name: _____ Project #: _____

Date: _____ Time: _____ hrs

Searcher: _____ Placed By: _____

Condition of Carcasses: Fresh Thawed Carcasses marked (and how)? _____

WEATHER

Temp: _____ °C *Wind Speed: _____ Wind Direction (from): _____ Visibility: High Medium Low

Cloud Cover (%): _____ Cloud Height: High Medium Low Precipitation: Rain Fog Snow None _____

Additional Weather or Other Comments: _____

	Time Placed (24hr)	Turbine #	Species	Distance From Turbine	Direction from Turbine	Habitat/Substrate	Visibility Class	UTM	Found By Searcher (Y/N)	Found After Search (Y/N)
1										
2										
3										
4										
5										
6										
7										
8										
9										
10										

*Beaufort Wind Scale: 0 calm; 1 smoke drifts; 2 wind felt on face; 3 leaves in motion; 4 small branches move; 5 small trees sway; 6 large branches move; 7 whole trees in motion; 8 twigs break off and hard to walk; 9 light structural damage; 10 tree uprooted

Placement Location Sketches (Draw access road for each sketch)

N ↑

1	2	3	4	5	6	7	8	9	10
X	X	X	X	X	X	X	X	X	X
T#___	T#___	T#___	T#___	T#___	T#___	T#___	T#___	T#___	T#___

Visibility Class Map

Project Name: _____ Project #: _____ Turbine #: _____ Degree of Slope _____ degrees Slope Orientation _____ (e.g. SSW)

Photo Numbers (from turbine base)
 Facing North: _____
 Facing East: _____
 Facing South: _____
 Facing West: _____
 (sketch habitat and visibility classes)

Date (DD/MM/YY): ___/___/___ ↑
 Observer: _____
 Monthly/Seasonal
 Linear Transect Width: _____ m

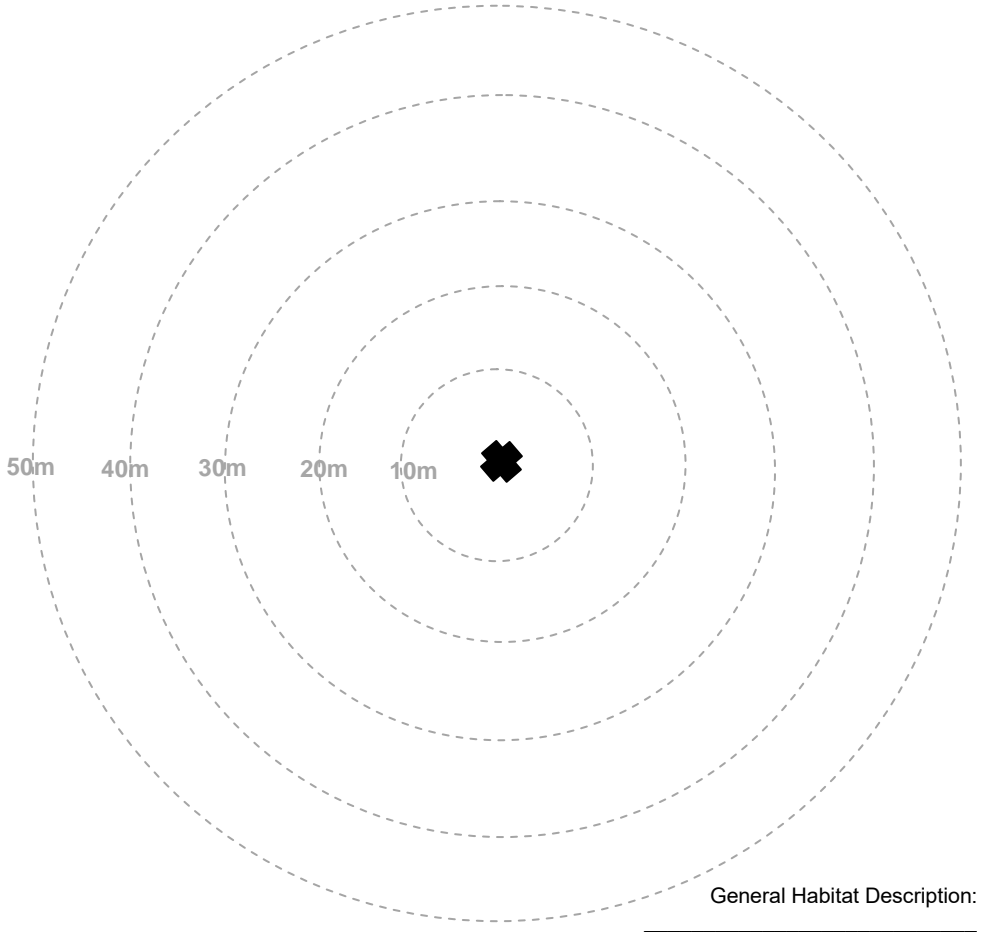
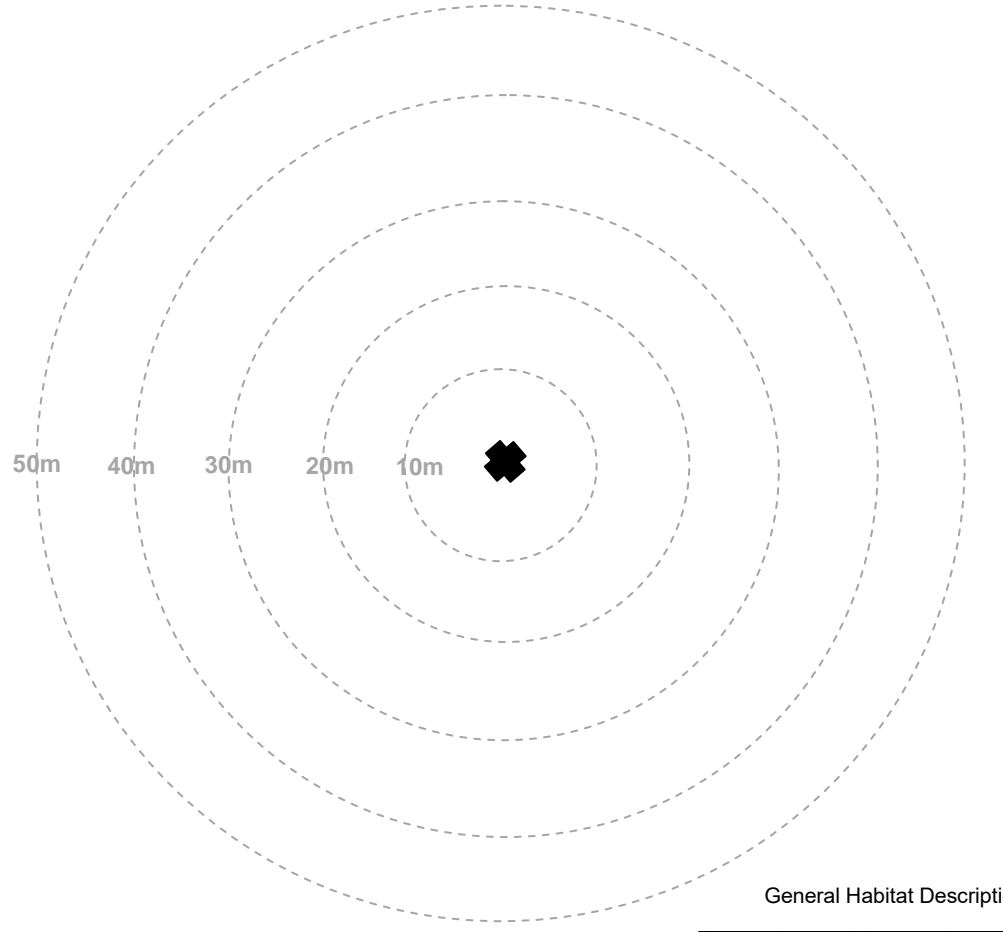


Photo Numbers (from turbine base)
 Facing North: _____
 Facing East: _____
 Facing South: _____
 Facing West: _____
 (sketch habitat and visibility classes)

Date (DD/MM/YY): ___/___/___ ↑
 Observer: _____
 Monthly/Seasonal
 Linear Transect Width: _____ m



VISIBILITY CLASSES	
Class 1	≥ 90% bare ground; vegetation ≤ 15cm tall
Class 2	≥ 25% bare ground; vegetation ≤ 15cm tall
Class 3	≤ 25% bare ground; less than 25% of veg. > 30cm tall
Class 4	Little or no bare ground; more than 25% of veg. > 30cm tall
Not Searchable	Dense shrubs, woods, or other unsearchable habitats

Appendix II
Scavenger Removal Trial Results

Appendix II
 1875C Gunn's Hill Wind Farm
 Scavenger Removal Trial Results 2019

Spring (May/June) 2019 Scavenger Removal Trial

Carcass Number	Turbine	Species	Distance from Turbine Base (m)	Direction from Turbine Base (°)	UTM (Zone 17T)		Visibility Class	Test Day	Date	Carcass Present	Signs of Scavenging	Tester
					Easting	Northing						
1	T03	Hoary Bat	47	40	523905	4769939	1	Day 0	03-May-19	Y	Carcass placed	Search Team A
								Day 4	07-May-19	Y	None	Search Team A
								Day 7	10-May-19	Y	None	Search Team A
								Day 11	14-May-19	Y	None	Search Team A
								Day 14	17-May-19	Y	None	Search Team A
2	T05	Philadelphia Vireo	5	90	525925	4768536	1	Day 0	03-May-19	Y	Carcass placed	Search Team A
								Day 4	07-May-19	Y	None	Search Team A
								Day 7	10-May-19	Y	None	Search Team A
								Day 11	14-May-19	Y	None	Search Team A
								Day 14	17-May-19	Y	None	Search Team A
3	T07	Silver-haired Bat	35	195	526973	4770265	1	Day 0	03-May-19	Y	Carcass placed	Search Team A
								Day 4	07-May-19	N	Carcass removed	Search Team A
								Day 7	10-May-19	N	N/A	Search Team A
								Day 11	14-May-19	N	N/A	Search Team A
								Day 14	17-May-19	N	N/A	Search Team A
4	T09	Hoary Bat	15	320	527426	4768946	1	Day 0	03-May-19	Y	Carcass placed	Search Team A
								Day 4	07-May-19	N	Carcass removed	Search Team A
								Day 7	10-May-19	N	N/A	Search Team A
								Day 11	14-May-19	N	N/A	Search Team A
								Day 14	17-May-19	N	N/A	Search Team A
5	T08	Downy Woodpecker	22	30	527121	4768888	1	Day 0	14-May-19	Y	Carcass placed	Search Team A
								Day 3	17-May-19	Y	None	Search Team A
								Day 7	21-May-19	Y	None	Search Team A
								Day 10	24-May-19	Y	None	Search Team A
								Day 14	28-May-19	Y	Only feathers remaining	Search Team A
6	T02	Eastern Red Bat	27	100	523766	4770215	1	Day 0	07-Jun-19	Y	Carcass placed	Search Team A
								Day 4	11-Jun-19	Y	None	Search Team A
								Day 7	14-Jun-19	Y	None	Search Team A
								Day 11	18-Jun-19	Y	None	Search Team A
								Day 14	21-Jun-19	Y	None	Search Team A
7	T03	Swainson's Thrush	32	150	523897	4769871	1	Day 0	07-Jun-19	Y	Carcass placed	Search Team A
								Day 4	11-Jun-19	Y	Partially scavenged; carcass moved approximately 20m	Search Team A
								Day 7	14-Jun-19	Y	No new signs	Search Team A
								Day 11	18-Jun-19	N	Carcass removed	Search Team A
								Day 14	21-Jun-19	N	N/A	Search Team A
8	T04	Silver-haired Bat	14	290	525519	4768603	1	Day 0	07-Jun-19	Y	Carcass placed	Search Team A
								Day 4	11-Jun-19	Y	None	Search Team A
								Day 7	14-Jun-19	Y	None	Search Team A
								Day 11	18-Jun-19	Y	None	Search Team A
								Day 14	21-Jun-19	Y	None	Search Team A
9	T06	Silver-haired Bat	49	60	526701	4770369	1	Day 0	07-Jun-19	Y	Carcass placed	Search Team A
								Day 4	11-Jun-19	Y	None	Search Team A
								Day 7	14-Jun-19	Y	None	Search Team A
								Day 11	18-Jun-19	Y	None	Search Team A
								Day 14	21-Jun-19	N	Carcass removed	Search Team A
10	T10	Golden-crowned Kinglet	7	260	528147	4769202	1	Day 0	07-Jun-19	Y	Carcass placed	Search Team A
								Day 4	11-Jun-19	Y	None	Search Team A
								Day 7	14-Jun-19	Y	None	Search Team A
								Day 11	18-Jun-19	Y	None	Search Team A
								Day 14	21-Jun-19	Y	None	Search Team A

Summer (July/August) 2019 Scavenger Removal Trial

Carcass Number	Turbine	Species	Distance from Turbine Base (m)	Direction from Turbine Base (°)	UTM (Zone 17T)		Visibility Class	Test Day	Date	Carcass Present	Signs of Scavenging	Tester
					Eastings	Northing						
1	T01	Ovenbird	21	140	523296	4769964	1	Day 0	02-Jul-19	Y	Carcass placed	Search Team C
								Day 3	05-Jul-19	N	Carcass removed	Search Team C
								Day 7	09-Jul-19	N	N/A	Search Team C
								Day 10	12-Jul-19	N	N/A	Search Team C
								Day 14	16-Jul-19	N	N/A	Search Team C
2	T04	Silver-haired Bat	38	288	525494	4768608	1	Day 0	02-Jul-19	Y	Carcass placed	Search Team C
								Day 3	05-Jul-19	Y	Head and neck partially scavenged	Search Team C
								Day 7	09-Jul-19	Y	No further signs	Search Team C
								Day 10	12-Jul-19	Y	Only wings remaining	Search Team C
								Day 14	16-Jul-19	Y	No further signs	Search Team C
3	T05	Hoary Bat	46	95	525967	4768549	1	Day 0	02-Jul-19	Y	Carcass placed	Search Team C
								Day 3	05-Jul-19	Y	None	Search Team C
								Day 7	09-Jul-19	N	Carcass removed	Search Team C
								Day 10	12-Jul-19	N	N/A	Search Team C
								Day 14	16-Jul-19	N	N/A	Search Team C
4	T06	Ovenbird	13	36	526658	4770353	1	Day 0	02-Jul-19	Y	Carcass placed	Search Team C
								Day 3	05-Jul-19	N	Carcass removed	Search Team C
								Day 7	09-Jul-19	N	N/A	Search Team C
								Day 10	12-Jul-19	N	N/A	Search Team C
								Day 14	16-Jul-19	N	N/A	Search Team C
5	T10	Hoary Bat	7	55	528160	4769208	1	Day 0	02-Jul-19	Y	Carcass placed	Search Team C
								Day 3	05-Jul-19	Y	None	Search Team C
								Day 7	09-Jul-19	Y	None	Search Team C
								Day 10	12-Jul-19	Y	None	Search Team C
								Day 14	16-Jul-19	Y	None	Search Team C
6	T02	Silver-haired Bat	45	30	523818	4770245	1	Day 0	02-Aug-19	Y	Carcass placed	Search Team C
								Day 4	06-Aug-19	Y	None	Search Team C
								Day 7	09-Aug-19	Y	None	Search Team C
								Day 11	13-Aug-19	N	Carcass removed	Search Team C
								Day 14	16-Aug-19	N	N/A	Search Team C
7	T03	Hoary Bat	26	95	523901	4769897	1	Day 0	02-Aug-19	Y	Carcass placed	Search Team C
								Day 4	06-Aug-19	N	Carcass removed	Search Team C
								Day 7	09-Aug-19	N	N/A	Search Team C
								Day 11	13-Aug-19	N	N/A	Search Team C
								Day 14	16-Aug-19	N	N/A	Search Team C
8	T07	Hoary Bat	34	260	526946	4770281	1	Day 0	02-Aug-19	Y	Carcass placed	Search Team C
								Day 4	06-Aug-19	N	Carcass removed	Search Team C
								Day 7	09-Aug-19	N	N/A	Search Team C
								Day 11	13-Aug-19	N	N/A	Search Team C
								Day 14	16-Aug-19	N	N/A	Search Team C
9	T08	Magnolia Warbler	23	70	527136	4768870	1	Day 0	02-Aug-19	Y	Carcass placed	Search Team C
								Day 4	06-Aug-19	N	Carcass removed	Search Team C
								Day 7	09-Aug-19	N	N/A	Search Team C
								Day 11	13-Aug-19	N	N/A	Search Team C
								Day 14	16-Aug-19	N	N/A	Search Team C
10	T09	Purple Martin	11	320	527429	4768944	1	Day 0	02-Aug-19	Y	Carcass placed	Search Team C
								Day 4	06-Aug-19	N	Carcass removed	Search Team C
								Day 7	09-Aug-19	N	N/A	Search Team C
								Day 11	13-Aug-19	N	N/A	Search Team C
								Day 14	16-Aug-19	N	N/A	Search Team C

Fall (September/October) 2019 Scavenger Removal Trial

Carcass Number	Turbine	Species	Distance from Turbine Base (m)	Direction from Turbine Base (°)	UTM (Zone 17T)		Visibility Class	Test Day	Date	Carcass Present	Signs of Scavenging	Tester
					Easting	Northing						
1	T01	Hoary Bat	45	30	523299	4770024	1	Day 0	03-Sep-19	Y	Carcass placed	Search Team C
								Day 3	06-Sep-19	Y	None	Search Team C
								Day 7	10-Sep-19	Y	None	Search Team C
								Day 10	13-Sep-19	N	Carcass removed	Search Team C
								Day 14	17-Sep-19	N	N/A	Search Team C
2	T03	White-throated Sparrow	32	200	523874	4769866	1	Day 0	03-Sep-19	Y	Carcass placed	Search Team C
								Day 3	06-Sep-19	Y	None	Search Team C
								Day 7	10-Sep-19	Y	None	Search Team C
								Day 10	13-Sep-19	N	Carcass removed	Search Team C
								Day 14	17-Sep-19	N	N/A	Search Team C
3	T05	Hoary Bat	36	210	525901	4768507	1	Day 0	03-Sep-19	Y	Carcass placed	Search Team C
								Day 3	06-Sep-19	Y	None	Search Team C
								Day 7	10-Sep-19	Y	None	Search Team C
								Day 10	13-Sep-19	N	Carcass removed	Search Team C
								Day 14	17-Sep-19	N	N/A	Search Team C
4	T07	Silver-haired Bat	23	140	526999	4770283	1	Day 0	03-Sep-19	Y	Carcass placed	Search Team C
								Day 3	06-Sep-19	Y	None	Search Team C
								Day 7	10-Sep-19	Y	None	Search Team C
								Day 10	13-Sep-19	Y	None	Search Team C
								Day 14	17-Sep-19	N	Carcass removed	Search Team C
5	T09	American Goldfinch	15	130	527440	4768926	1	Day 0	03-Sep-19	Y	Carcass placed	Search Team C
								Day 3	06-Sep-19	Y	None	Search Team C
								Day 7	10-Sep-19	N	Carcass removed	Search Team C
								Day 10	13-Sep-19	N	N/A	Search Team C
								Day 14	17-Sep-19	N	N/A	Search Team C
6	T02	Silver-haired Bat	38	190	523795	4770178	1	Day 0	01-Oct-19	Y	Carcass placed	Searcher A
								Day 3	04-Oct-19	N	Carcass removed; coyote tracks	Searcher A
								Day 7	08-Oct-19	N	N/A	Searcher A
								Day 10	11-Oct-19	N	N/A	Searcher A
								Day 14	15-Oct-19	N	N/A	Searcher A
7	T04	Hoary Bat	13	225	525526	4768592	1	Day 0	01-Oct-19	Y	Carcass placed	Searcher A
								Day 3	04-Oct-19	Y	None	Searcher A
								Day 7	08-Oct-19	Y	None	Searcher A
								Day 10	11-Oct-19	Y	None	Searcher A
								Day 14	15-Oct-19	Y	None	Searcher A
8	T06	Yellow-bellied Sapsucker	29	50	526674	4770366	1	Day 0	01-Oct-19	Y	Carcass placed	Searcher A
								Day 3	04-Oct-19	Y	None	Searcher A
								Day 7	08-Oct-19	N	Carcass removed	Searcher A
								Day 10	11-Oct-19	N	N/A	Searcher A
								Day 14	15-Oct-19	N	N/A	Searcher A
9	T08	Field Sparrow	3	285	527109	4768869	1	Day 0	01-Oct-19	Y	Carcass placed	Searcher A
								Day 3	04-Oct-19	N	Carcass removed	Searcher A
								Day 7	08-Oct-19	N	N/A	Searcher A
								Day 10	11-Oct-19	N	N/A	Searcher A
								Day 14	15-Oct-19	N	N/A	Searcher A
10	T10	Silver-haired Bat	46	150	528180	4769169	1	Day 0	01-Oct-19	Y	Carcass placed	Searcher A
								Day 3	04-Oct-19	N	Carcass removed	Searcher A
								Day 7	08-Oct-19	N	N/A	Searcher A
								Day 10	11-Oct-19	N	N/A	Searcher A
								Day 14	15-Oct-19	N	N/A	Searcher A

Appendix III
Searcher Efficiency Trial Results

**Appendix III
1875C Gunn's Hill Wind Farm
Searcher Efficiency Trial Results 2019**

Date	Searcher	No.	Turbine	Species	Distance (m)	Direction (°)	General Habitat	Visibility Class	UTM (Zone 17T)		Found (Y/N)	Scavenged (Y/N)
									Easting	Northing		
10-May-19	Search Team A	1	T01	Hoary Bat	7	52	Gravel	1	523286	4769983	Y	-
		2	T03	Eastern Red Bat	46	10	Bare soil	1	523877	4769945	Y	-
		3	T08	Hermit Thrush	12	270	Bare soil	1	527101	4768888	Y	-
14-May-19	Search Team A	4	T06	Hoary Bat	9	130	Bare soil	1	526663	4770333	Y	-
		5	T07	American Robin	29	335	Bare soil	1	526966	4770329	Y	-
		6	T09	Silver-haired Bat	48	320	Bare soil	1	527406	4768978	N	N
21-May-19	Search Team A	7	T02	White-throated Sparrow	38	250	Bare soil	1	523758	4770195	Y	-
		8	T10	Lincoln's Sparrow	29	210	Bare soil	1	528141	4769182	Y	-
24-May-19	Search Team A	9	T04	White-throated Sparrow	12	190	Bare soil	1	525534	4768592	Y	-
		10	T05	Marsh Wren	46	355	Bare soil	1	525907	4768572	Y	-

Date	Searcher	No.	Turbine	Species	Distance (m)	Direction (°)	General Habitat	Visibility Class	UTM (Zone 17T)		Found (Y/N)	Scavenged (Y/N)
									Easting	Northing		
4-Jun-19	Search Team A	1	T02	Eastern Red Bat	41	80	Bare soil	1	523833	4770227	Y	-
		2	T07	American Robin	11	280	Bare soil	1	526970	4770296	Y	-
		3	T08	Hoary Bat	26	170	Bare soil	1	527122	4768851	Y	-
11-Jun-19	Search Team A	4	T01	Silver-haired Bat	45	210	Bare soil	1	523250	4769942	N	N
		5	T03	Hermit Thrush	11	350	Gravel	1	523880	4769908	Y	-
		6	T06	Golden-crowned Kinglet	6	340	Gravel	1	526654	4770341	Y	-
14-Jun-19	Search Team A	7	T09	Blue Jay	11	200	Bare soil	1	527437	4768929	Y	-
		8	T10	Golden-crowned Kinglet	34	190	Bare soil	1	528153	4769174	Y	-
21-Jun-19	Search Team A	9	T04	Chestnut-sided Warbler	12	60	Bare soil	1	525546	4768606	Y	-
		10	T05	Cliff Swallow	45	320	Bare soil	1	525884	4768575	Y	-

Date	Searcher	No.	Turbine	Species	Distance (m)	Direction (°)	General Habitat	Visibility Class	UTM (Zone 17T)		Found (Y/N)	Scavenged (Y/N)
									Easting	Northing		
9-Jul-19	Search Team C	1	T01	Cedar Waxwing	33	220	Bare soil	1	523249	4769962	N	N
		2	T02	Hoary Bat	48	335	Bare soil	1	523763	4770256	Y	-
		3	T03	Swainson's Thrush	18	85	Bare soil	1	523895	4769898	Y	-
16-Jul-19	Search Team C	4	T04	Hoary Bat	43	120	Bare soil	1	525569	4768578	N	N
		5	T05	Silver-haired Bat	22	325	Bare soil	1	525900	4768554	Y	-
		6	T08	Mourning Dove	9	45	Bare soil	1	527120	4768879	Y	-
19-Jul-19	Search Team C	7	T06	Silver-haired Bat	25	110	Gravel	1	526678	4770335	Y	-
		8	T09	Magnolia Warbler	34	320	Bare soil	1	527422	4768964	Y	-
23-Jul-19	Search Team C	9	T10	Purple Martin	39	160	Bare soil	1	528175	4769174	Y	-
		10	T07	Swainson's Thrush	24	130	Bare soil	1	526959	4770257	Y	-

Date	Searcher	No.	Turbine	Species	Distance (m)	Direction (°)	General Habitat	Visibility Class	UTM (Zone 17T)		Found (Y/N)	Scavenged (Y/N)
									Easting	Northing		
9-Aug-19	Search Team C	1	T04	Tree Swallow	13	185	Bare soil	1	525533	4768589	Y	-
		2	T05	Hoary Bat	35	310	Bare soil	1	525887	4768558	N	N
		3	T08	Red-eyed Vireo	42	45	Bare soil	1	527135	4768909	N	N
13-Aug-19	Search Team C	4	T01	Silver-haired Bat	7	230	Gravel	1	523273	4769969	Y	-
		5	T02	Brown-headed Cowbird	27	60	Bare soil	1	523816	4770235	Y	-
		6	T03	Yellow-bellied Sapsucker	42	240	Bare soil	1	523840	4769876	Y	-
16-Aug-19	Search Team C	7	T09	Hoary Bat	34	10	Bare soil	1	527445	4768975	Y	-
		8	T10	Purple Martin	16	330	Bare soil	1	528143	4769217	N	Y
23-Aug-19	Search Team C	9	T06	White-throated Sparrow	22	185	Bare soil	1	526654	4770323	N	N
		10	T07	American Goldfinch	36	310	Bare soil	1	526944	4770317	Y	-
		11	T10	Silver-haired Bat	12	290	Bare soil	1	528141	4769205	Y	-

Date	Searcher	No.	Turbine	Species	Distance (m)	Direction (°)	General Habitat	Visibility Class	UTM (Zone 17T)		Found (Y/N)	Scavenged (Y/N)
									Easting	Northing		
6-Sep-19	Search Team C	1	T01	Hoary Bat	43	225	Bare soil	1	523251	4769945	Y	-
		2	T02	Silver-haired Bat	31	110	Bare soil	1	523824	4770218	N	N
		3	T07	Yellow-bellied Sapsucker	23	32	Bare soil	1	526989	4770325	Y	-
13-Sep-19	Search Team C	4	T04	Hermit Thrush	19	285	Bare soil	1	525512	4768601	Y	-
		5	T06	Fox Sparrow	8	195	Gravel	1	526657	4770334	Y	-
		6	T09	Hoary Bat	39	340	Gravel	1	527427	4768978	Y	-
20-Sep-19	Search Team C	7	T05	Silver-haired Bat	42	65	Bare soil	1	525950	4768565	Y	-
		8	T08	Gray Catbird	13	350	Bare soil	1	527108	4768884	Y	-
24-Sep-19	Search Team C	9	T03	Least Flycatcher	48	310	Bare soil	1	523833	4769931	N	N
		10	T10	Yellow-billed Cuckoo	32	130	Bare soil	1	528177	4769185	Y	-

Date	Searcher	No.	Turbine	Species	Distance (m)	Direction (°)	General Habitat	Visibility Class	UTM (Zone 17T)		Found (Y/N)	Scavenged (Y/N)
									Easting	Northing		
8-Oct-19	Searcher A	1	T06	Red-breasted Nuthatch	39	80	Bare soil	1	526696	4770339	N	N
		2	T07	Hoary Bat	9	260	Gravel	1	526974	4770294	Y	-
		3	T10	Red-breasted Nuthatch	47	130	Bare soil	1	528173	4769163	Y	-
11-Oct-19	Searcher A	4	T01	Hoary Bat	24	40	Bare soil	1	523295	4770006	Y	-
		5	T02	Dark-eyed Junco	48	110	Bare soil	1	523842	4770200	Y	-
		6	T03	Silver-haired Bat	15	300	Bare soil	1	523862	4769903	Y	-
18-Oct-19	Searcher A	7	T04	Silver-haired Bat	22	215	Bare soil	1	525521	4768579	Y	-
		8	T05	Hermit Thrush	46	40	Bare soil	1	525944	4768575	Y	-
25-Oct-19	Searcher A	9	T08	Red-breasted Nuthatch	14	350	Bare soil	1	527108	4768884	Y	-
		10	T09	Warbling Vireo	34	220	Bare soil	1	527424	4768908	Y	-

Appendix IV
Avian Mortalities

Appendix IV
1875C Gunn's Hill WF
2019 Avian Mortalities

Visibility Class: 1 ≥90% bare ground, vegetation ≤15cm tall
2 ≥25% bare ground, vegetation ≤15cm tall
3 ≤25% bare ground, ≤25% of vegetation is >30cm tall
4 little or no bare ground, ≥ 25% of vegetation is >30cm tall

Condition Code: I Injured or dying
F Freshly dead
E Early decomposition
M Moderate decomposition
A Advanced decomposition
C Complete decomposition
S Scavenged

Date	Turbine	Start Time	End Time	Dog Used (Y/N)	Days Since Last Search	Temp. (°C)	Cloud Cover (%)	Precipitation	Wind Speed (Beaufort Scale)	Wind Direction	Species	Sample ID	Sex (M/F/U)	Easting	Northing	Distance from Turbine (m)	Direction from Turbine (°)	Condition Code	Estimated Time Since Death (hrs)	Observed Injuries	Substrate/Habitat	Visibility Class
3-May-19	T01	8:38	8:58	N	3	6	100	Rain	2	N	Passerine species	1875-030519-T01-01	U	523272	4769998	23	340	C	720	None apparent	Bare soil	1
10-May-19	T10	12:38	12:58	N	3	12	100	None	4	NW	House Wren	1875-100519-T10-01	U	528176	4769220	33	60	F	24	Neck broken	Bare soil	1
28-May-19	T10	12:33	12:53	N	4	10	100	Rain/Fog	4	NE	Red-eyed Vireo	1875-280519-T10-01	U	528159	4769217	11	30	E	30	Neck broken; back laceration; tail missing	Bare soil	1
18-Jun-19	T10	12:12	12:32	N	4	17	90	None	2	SE	Horned Lark	1875-180619-T10-01	U	528112	4769174	48	240	M	72	Left wing broken	Bare soil	1
12-Jul-19	T05	11:15	11:35	N	3	23	95	None	3	SW	Warbler species	1875-120719-T05-01	U	525923	4768541	5	70	C	336	None apparent	Bare soil	1
20-Sep-19	T04	11:10	11:30	N	3	16	20	None	2	SW	Red-eyed Vireo	1875-200919-T04-01	U	525495	4768632	41	300	F	24	None apparent	Bare soil	1
4-Oct-19	T09	12:17	12:37	N	3	9	80	None	3	N	Mourning Dove	1875-041019-T09-01	U	527413	4768908	36	220	S	24	Only feathers and some organs remaining	Bare soil	1
11-Oct-19	T09	12:02	12:22	N	3	9	15	None	3	E	Red-eyed Vireo	1875-111019-T09-01	U	527407	4768947	28	295	F	6	None apparent	Bare soil	1
22-Oct-19	T07	9:51	10:11	N	4	15	100	None	4	S	Swamp Sparrow	1875-221019-T07-01	U	527022	4770286	44	150	F	24	Legs broken; parts of tail missing	Bare soil	1
25-Oct-19	T09	10:50	11:10	N	3	6	60	None	2	SE	Golden-crowned Kinglet	1875-251019-T09-02	U	527451	4768900	42	150	E	48	Neck broken	Bare soil	1

Appendix V
Bat Mortalities

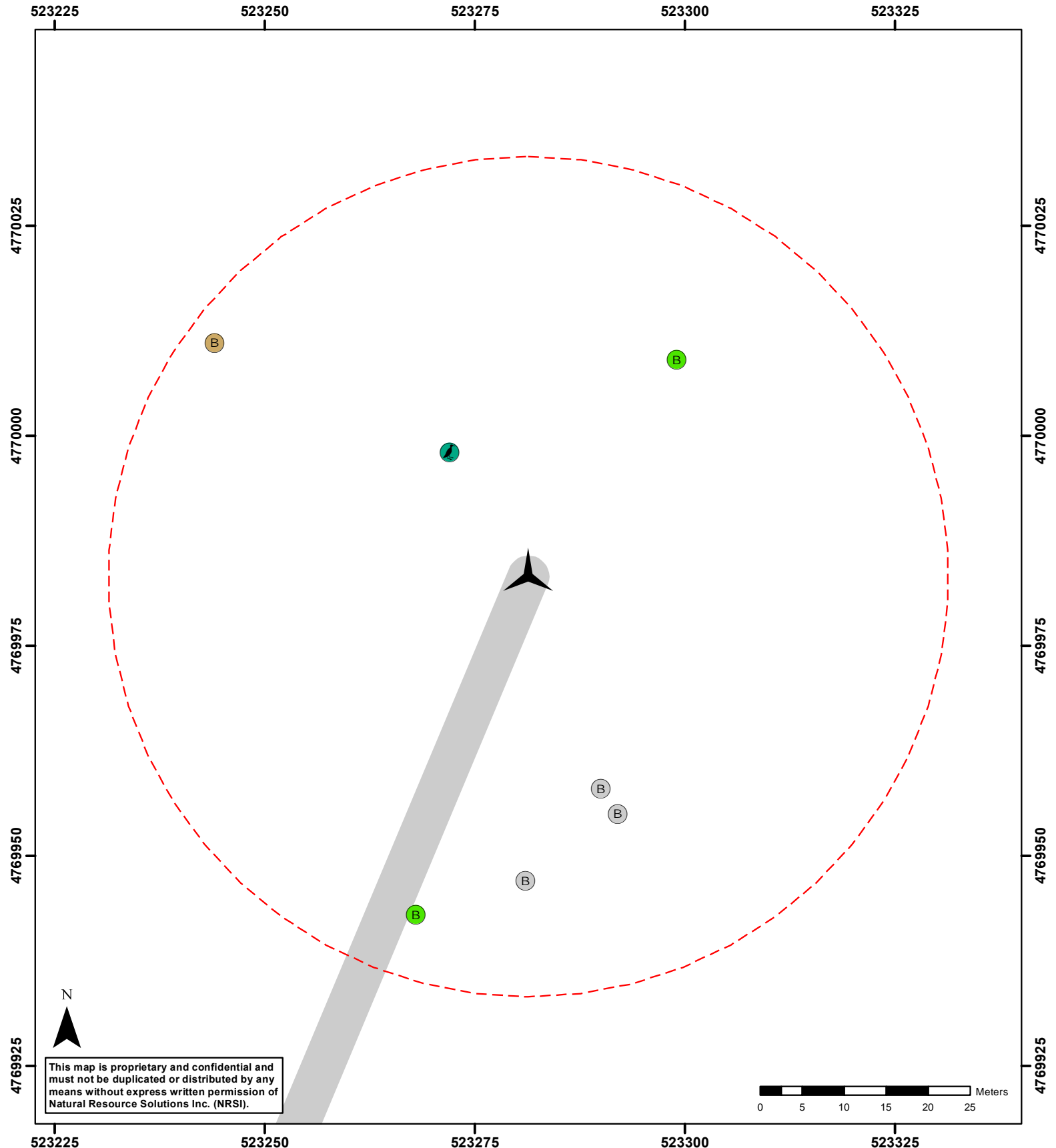
**Appendix V
1875C Gunn's Hill WF
2019 Bat Mortalities**

Visibility Class: 1 ≥90% bare ground, vegetation ≤15cm tall
 2 ≥25% bare ground, vegetation ≤15cm tall
 3 ≥25% bare ground, ≤25% of vegetation is >30cm tall
 4 little or no bare ground, ≥ 25% of vegetation is >30cm tall

Condition Code: I Injured or dying
 F Freshly dead
 E Early decomposition
 M Moderate decomposition
 A Advanced decomposition
 C Complete decomposition
 S Scavenged

Date	Turbine	Start Time	End Time	Dog Used (Y/N)	Days Since Last Search	Temp. (°C)	Cloud Cover (%)	Precipitation	Wind Speed (Beaufort Scale)	Wind Direction	Species	Sample ID	Bat FA (mm)	Sex (M/F/U)	Easting	Northing	Distance from Turbine (m)	Direction from Turbine (°)	Condition Code	Estimated Time Since Death (hrs)	Observed Injuries	Substrate/Habitat	Visibility Class
21-May-19	T05	11:37	11:57	N	4	9	5	None	3	NW	Silver-haired Bat	1875-210519-T05-01	41	U	525903	4768507	37	210	E	40	Abdominal laceration	Bare soil	1
25-Jun-19	T04	10:06	10:26	N	4	19	25	None	3	SW	Hoary Bat	1875-250619-T04-01	54	F	525521	4768602	13	290	M	84	None apparent	Bare soil	1
5-Jul-19	T01	8:15	8:35	N	3	32	20	None	3	SW	Big Brown Bat	1875-050719-T01-01	43	M	523244	4770011	46	328	E	40	Abdominal laceration	Bare soil	1
9-Jul-19	T04	11:50	12:10	N	4	25	0	None	1	NE	Hoary Bat	1875-090719-T04-01	55	U	525503	4768601	30	280	E	36	Abdominal laceration	Bare soil	1
12-Jul-19	T04	10:50	11:10	N	3	23	95	None	3	SW	Hoary Bat	1875-120719-T04-01	54	U	525545	4768592	18	155	A	110	None apparent	Bare soil	1
16-Jul-19	T02	9:15	9:35	N	4	28	90	None	2	SW	Hoary Bat	1875-160719-T02-01	55	M	523819	4770242	42	45	F	8	None apparent	Bare soil	1
16-Jul-19	T05	11:30	11:50	N	4	28	90	None	2	SW	Hoary Bat	1875-160719-T05-01	51	M	525893	4768505	45	220	F	10	Back laceration	Bare soil	1
19-Jul-19	T03	9:00	9:20	N	3	32	75	None	2	SW	Hoary Bat	1875-190719-T03-01	52	F	523866	4769911	21	340	F	8	None apparent	Bare soil	1
26-Jul-19	T10	11:25	11:45	N	3	25	0	None	2	SW	Hoary Bat	1875-260719-T10-01	60	M	528189	4769233	43	50	F	12	Abdominal laceration	Bare soil	1
2-Aug-19	T09	11:30	11:50	N	3	20	5	None	1	NE	Hoary Bat	1875-020819-T09-01	52	M	527417	4768939	21	315	F	12	Head injury	Bare soil	1
6-Aug-19	T01	8:15	8:35	N	4	23	50	Rain	2	SW	Hoary Bat	1875-060819-T01-01	53	U	523299	4770009	32	30	F	10	None apparent	Bare soil	1
13-Aug-19	T07	10:05	10:25	N	4	21	60	None	2	SW	Hoary Bat	1875-130819-T07-01	53	F	527001	4770309	30	80	F	12	None apparent	Bare soil	1
16-Aug-19	T05	9:35	9:55	N	3	20	20	None	2	SW	Hoary Bat	1875-160819-T05-01	50	U	525929	4770343	42	170	E	36	Abdominal laceration	Bare soil	1
20-Aug-19	T03	8:55	9:15	N	4	20	25	Fog	2	SW	Eastern Red Bat	1875-200819-T03-01	38	F	523899	4769934	41	50	E	40	Broken left upper arm	Bare soil	1
23-Aug-19	T01	8:15	8:35	N	3	15	5	None	2	SW	Hoary Bat	1875-230819-T01-01	57	F	523268	4769943	31	190	F	8	None apparent	Gravel	1
27-Aug-19	T02	8:35	8:55	N	4	18	100	Rain/Fog	2	SW	Big Brown Bat	1875-270819-T02-01	42	F	523755	4770190	37	250	F	12	None apparent	Bare soil	1
30-Aug-19	T02	8:20	8:40	N	3	19	5	None	2	SW	Silver-haired Bat	1875-300819-T02-01	40	M	523839	4770222	45	95	F	12	None apparent	Bare soil	1
3-Sep-19	T01	8:20	8:40	N	3	18	25	None	2	SW	Silver-haired Bat	1875-030919-T01-01	43	M	523281	4769947	29	190	F	10	None apparent	Bare soil	1
3-Sep-19	T02	8:50	9:10	N	3	18	25	None	2	SW	Silver-haired Bat	1875-030919-T02-01	39	M	523818	4770228	27	70	E	36	Left wing injured	Bare soil	1
3-Sep-19	T09	11:45	12:05	N	3	18	25	None	2	SW	Hoary Bat	1875-030919-T09-01	59	U	527429	4768911	25	200	F	10	None apparent	Bare soil	1
10-Sep-19	T01	8:15	8:35	N	4	15	25	None	1	SW	Silver-haired Bat	1875-100919-T01-01	38	U	523290	4769958	29	170	M	65	None apparent	Bare soil	1
10-Sep-19	T02	8:50	9:10	N	4	15	25	None	1	SW	Big Brown Bat	1875-100919-T02-01	44	M	528174	4770249	38	340	F	12	None apparent	Bare soil	1
13-Sep-19	T07	9:45	10:05	N	3	12	100	None	3	SW	Hoary Bat	1875-130919-T07-01	53	U	526971	4770268	23	210	E	40	Abdominal laceration	Bare soil	1
27-Sep-19	T06	11:55	12:15	N	3	17	10	None	3	SW	Silver-haired Bat	1875-270919-T06-01	43	U	526667	4770743	13	90	F	10	Lower abdomen missing	Gravel	1
4-Oct-19	T03	9:02	9:22	N	3	9	80	None	3	N	Silver-haired Bat	1875-041019-T03-01	41	F	523897	4769896	20	90	F	12	Abdominal laceration	Bare soil	1
22-Oct-19	T01	8:09	8:29	N	4	15	100	None	4	S	Silver-haired Bat	1875-221019-T01-01	43	F	523292	4769955	27	160	F	12	None apparent	Bare soil	1
25-Oct-19	T09	10:50	11:10	N	3	6	60	None	2	SE	Silver-haired Bat	1875-251019-T09-01	42	F	527440	4768974	35	10	F	12	None apparent	Bare soil	1






Appendix VI
Locations of Bird and Bat Mortalities



This map is proprietary and confidential and must not be duplicated or distributed by any means without express written permission of Natural Resource Solutions Inc. (NRSI).



Legend


-  Turbine
-  Search Radius (50m)
-  Access Road
-  Big Brown Bat
-  Hoary Bat
-  Silver-haired Bat
-  Passerine species

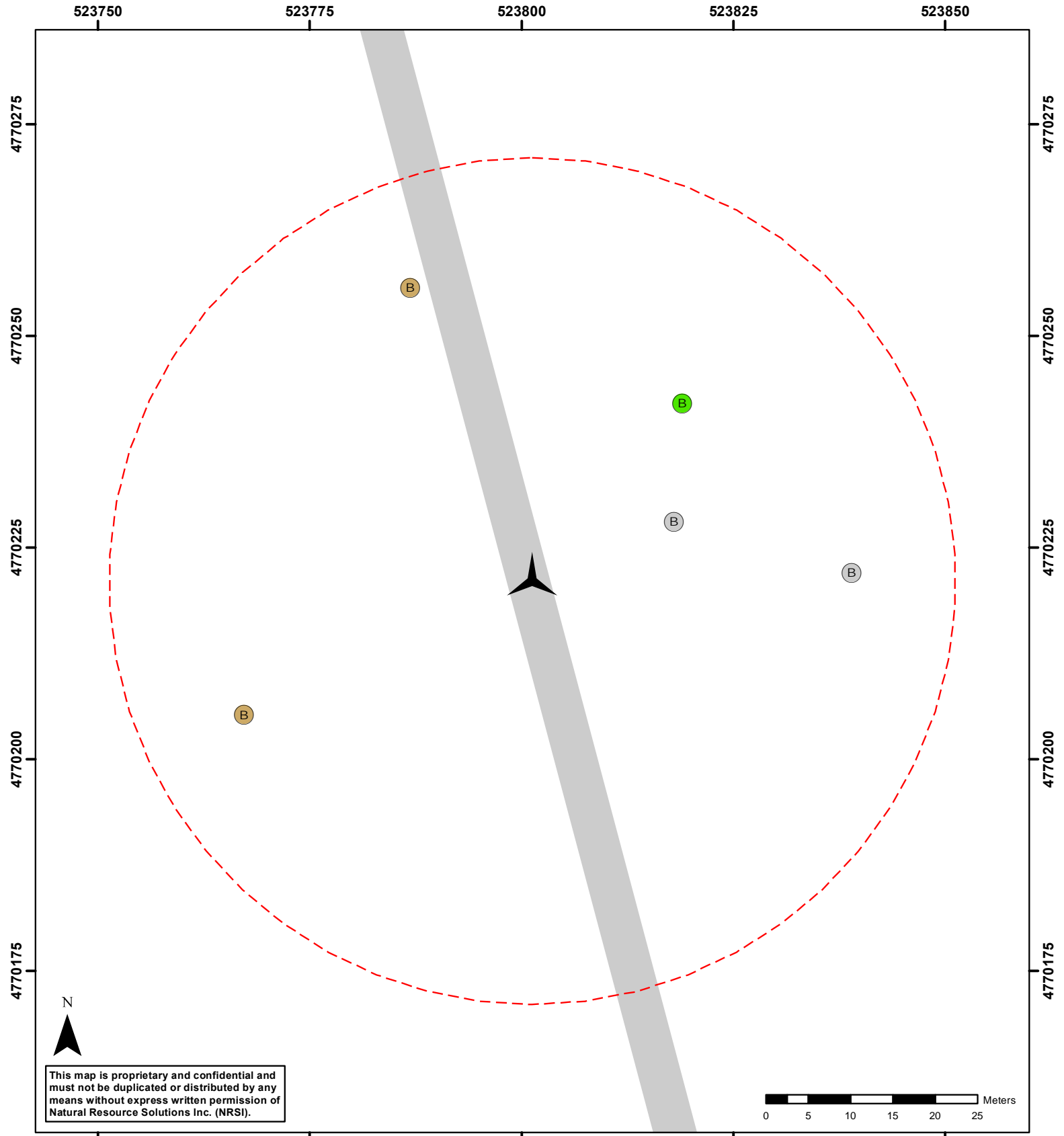
Appendix VI

Gunn's Hill WF

Turbine 01 Mortalities 2019

NAD83 - UTM Zone 17 Scale: 1:600 (8.5x11")	Date: December 5, 2019 Project: 1875C
---	--





This map is proprietary and confidential and must not be duplicated or distributed by any means without express written permission of Natural Resource Solutions Inc. (NRSI).



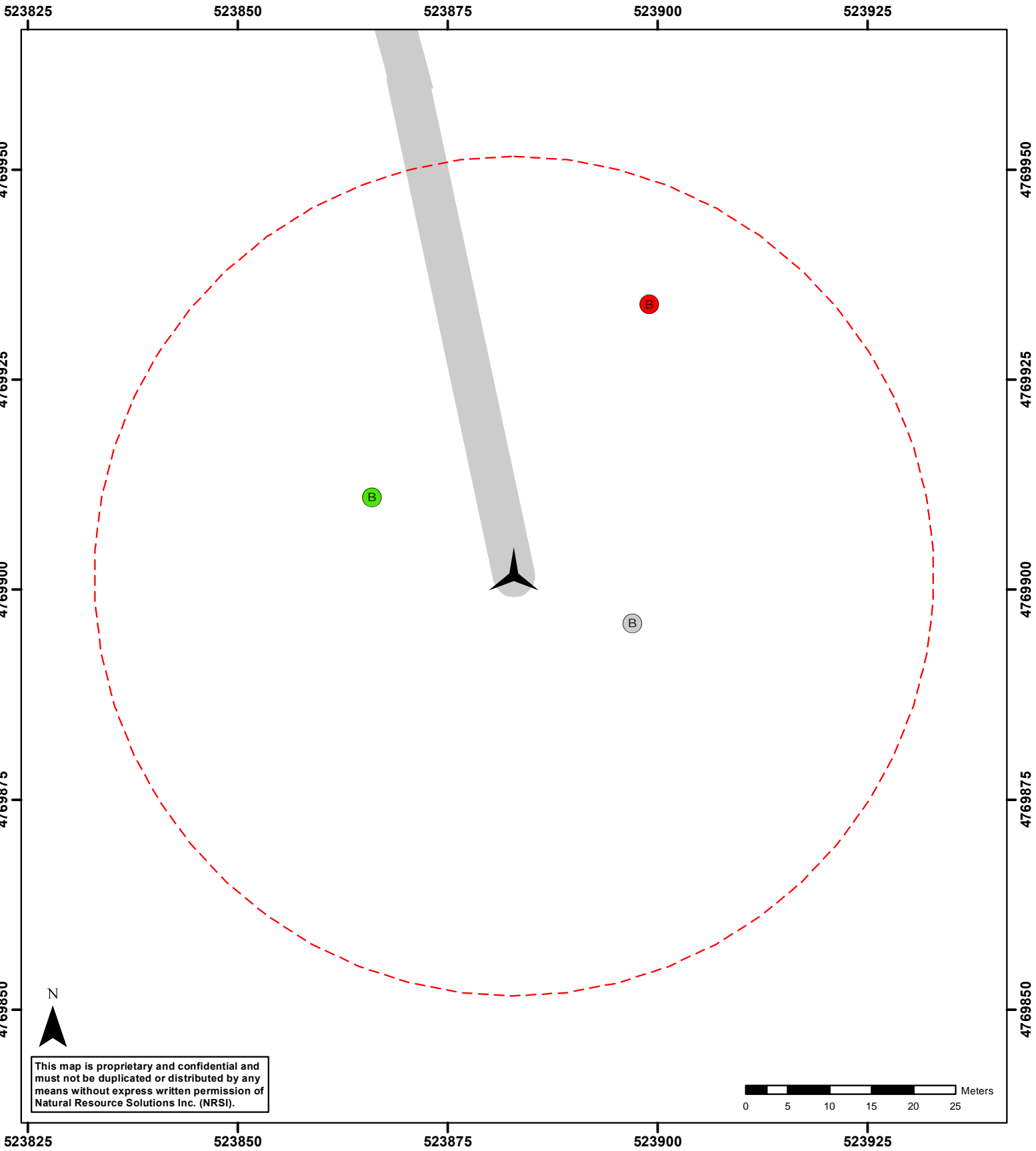
- Legend**
- Turbine
 - Search Radius (50m)
 - Access Road
 - Big Brown Bat
 - Hoary Bat
 - Silver-haired Bat

Appendix VI

Gunn's Hill WF

Turbine 02 Mortalities 2019







NAD83 - UTM Zone 17 Scale: 1:600 (8.5x11")	Date: November 27, 2019 Project: 1875C
---	---



This map is proprietary and confidential and must not be duplicated or distributed by any means without express written permission of Natural Resource Solutions Inc. (NRSI).



Legend


-  Turbine
-  Search Radius (50m)
-  Access Road
-  Eastern Red Bat
-  Hoary Bat
-  Silver-haired Bat

Appendix VI

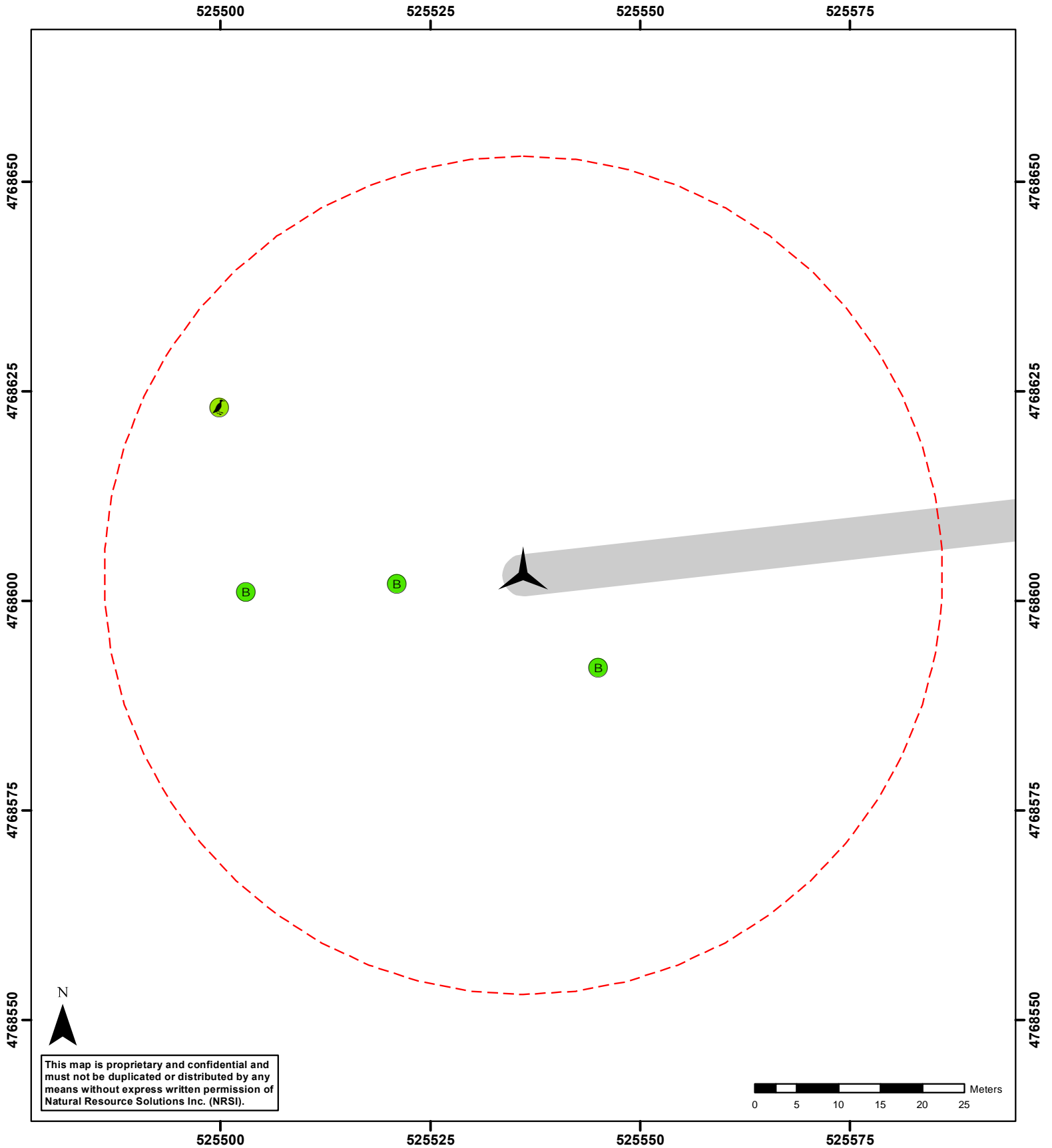
Gunn's Hill WF

Turbine 03 Mortalities 2019

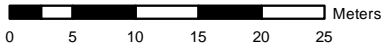
NAD83 - UTM Zone 17 Scale: 1:600 (8.5x11")	Date: November 27, 2019 Project: 1875C
---	---



NATURAL RESOURCE SOLUTIONS INC.
Aquatic, Terrestrial and Wetland Biologists



This map is proprietary and confidential and must not be duplicated or distributed by any means without express written permission of Natural Resource Solutions Inc. (NRSI).



Legend

-  Turbine
-  Hoary Bat
-  Search Radius (50m)
-  Red-eyed Vireo
-  Access Road

Appendix VI

Gunn's Hill WF
Turbine 04 Mortalities 2019

NAD83 - UTM Zone 17
Scale: 1:600 (8.5x11")

Date: November 27, 2019
Project: 1875C



525875

525900

525925

525950

525975

4768600

4768600

4768575

4768575

4768550

4768550

4768525

4768525

4768500

4768500

4768475

4768475

525875

525900

525925

525950






525975



This map is proprietary and confidential and must not be duplicated or distributed by any means without express written permission of Natural Resource Solutions Inc. (NRSI).



Legend

-  Turbine
-  Search Radius (50m)
-  Access Road
-  Hoary Bat
-  Silver-haired Bat
-  Warbler species


Appendix VI

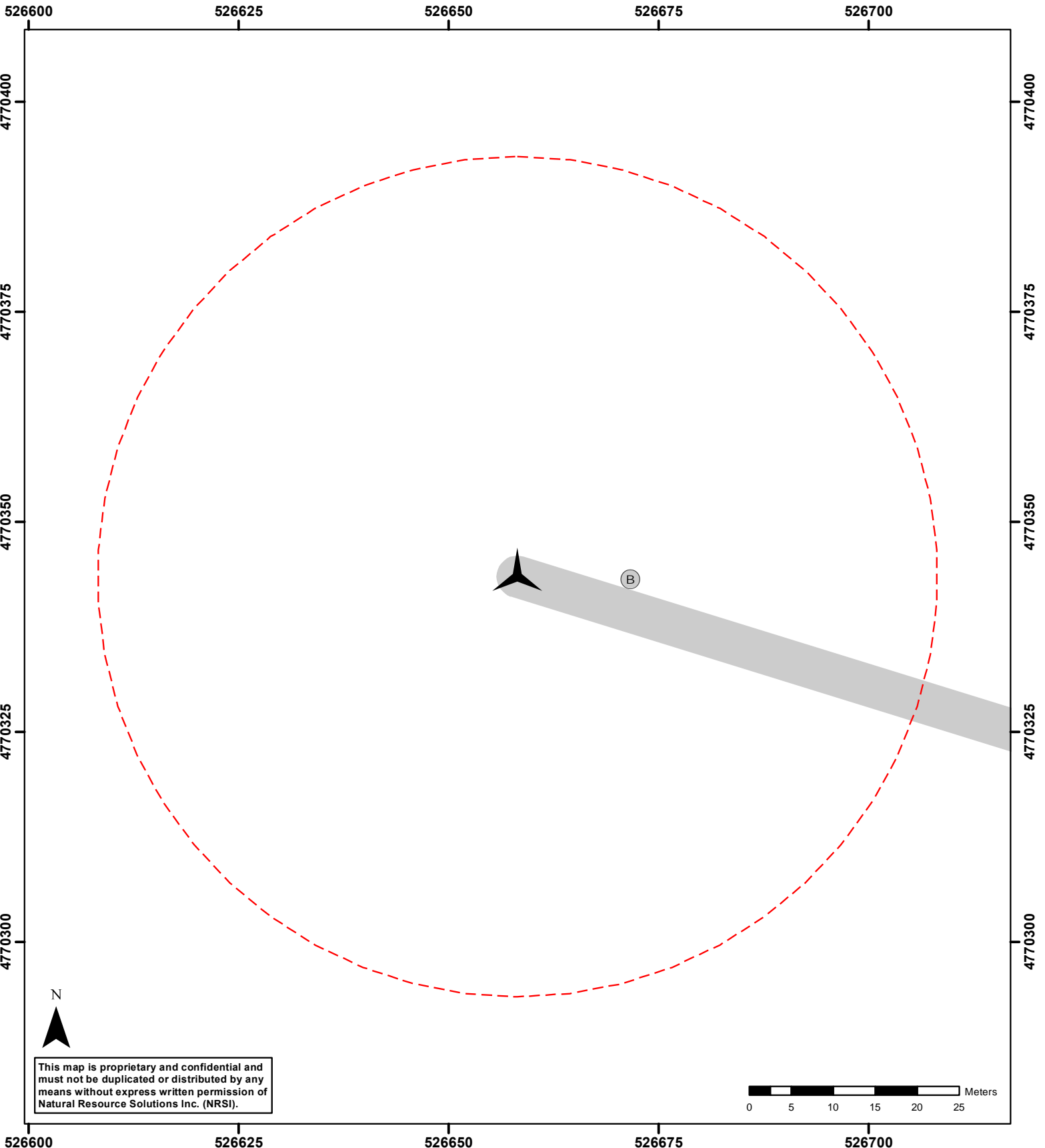
Gunn's Hill WF

Turbine 05 Mortalities 2019

NAD83 - UTM Zone 17
Scale: 1:600 (8.5x11")

Date: December 4, 2019
Project: 1875C









This map is proprietary and confidential and must not be duplicated or distributed by any means without express written permission of Natural Resource Solutions Inc. (NRSI).



Legend


-  Turbine
-  Silver-haired Bat
-  Search Radius (50m)
-  Access Road

Appendix VI

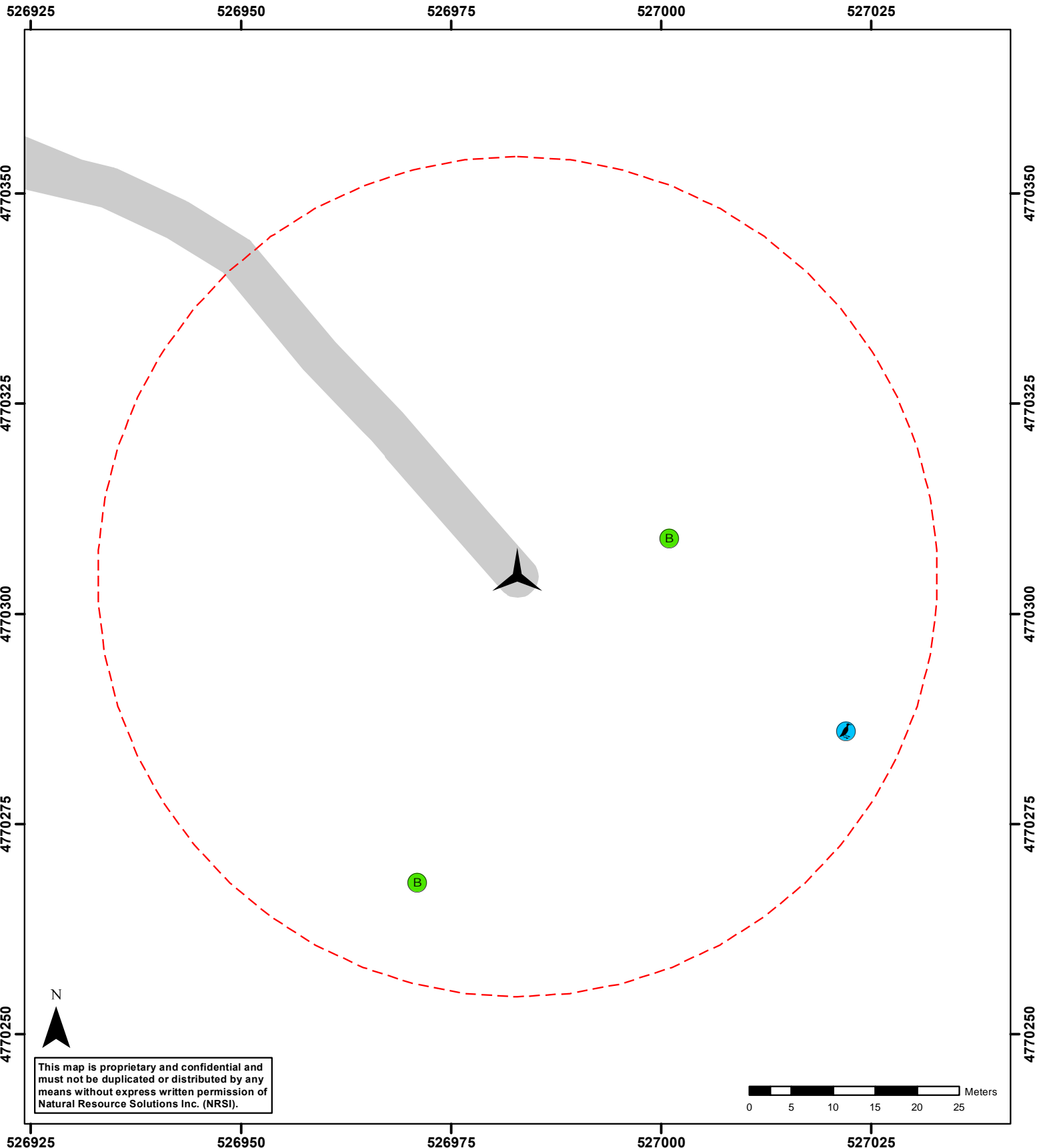
Gunn's Hill WF

Turbine 06 Mortalities 2019

NAD83 - UTM Zone 17 Scale: 1:600 (8.5x11")	Date: November 27, 2019 Project: 1875C
---	---








Aquatic, Terrestrial and Wetland Biologists



This map is proprietary and confidential and must not be duplicated or distributed by any means without express written permission of Natural Resource Solutions Inc. (NRSI).

Legend


-  Turbine
-  Hoary Bat
-  Search Radius (50m)
-  House Sparrow
-  Access Road

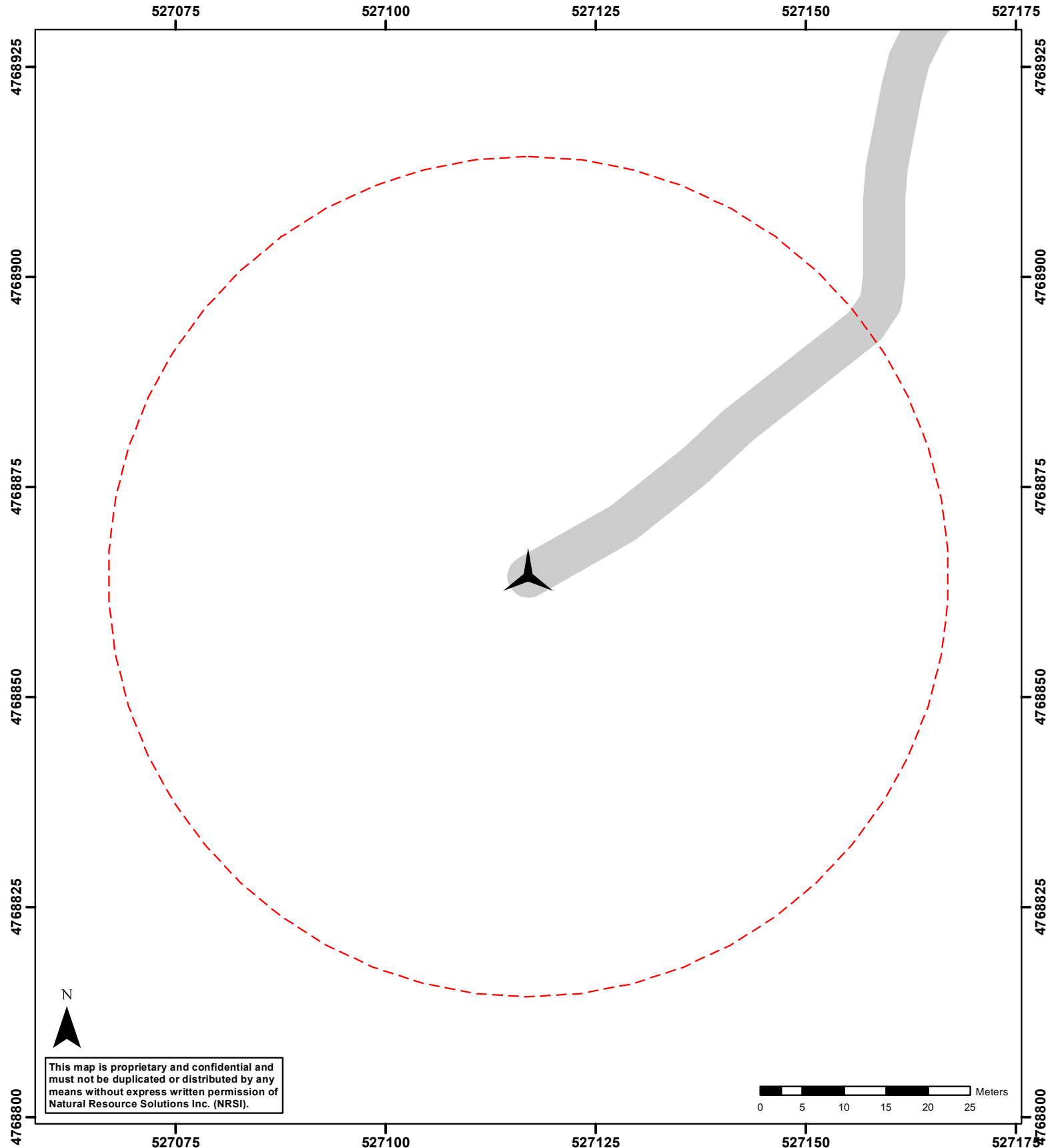
Appendix VI

Gunn's Hill WF

Turbine 07 Mortalities 2019




NAD83 - UTM Zone 17 Scale: 1:600 (8.5x11")	Date: November 27, 2019 Project: 1875C
---	---





This map is proprietary and confidential and must not be duplicated or distributed by any means without express written permission of Natural Resource Solutions Inc. (NRSI).



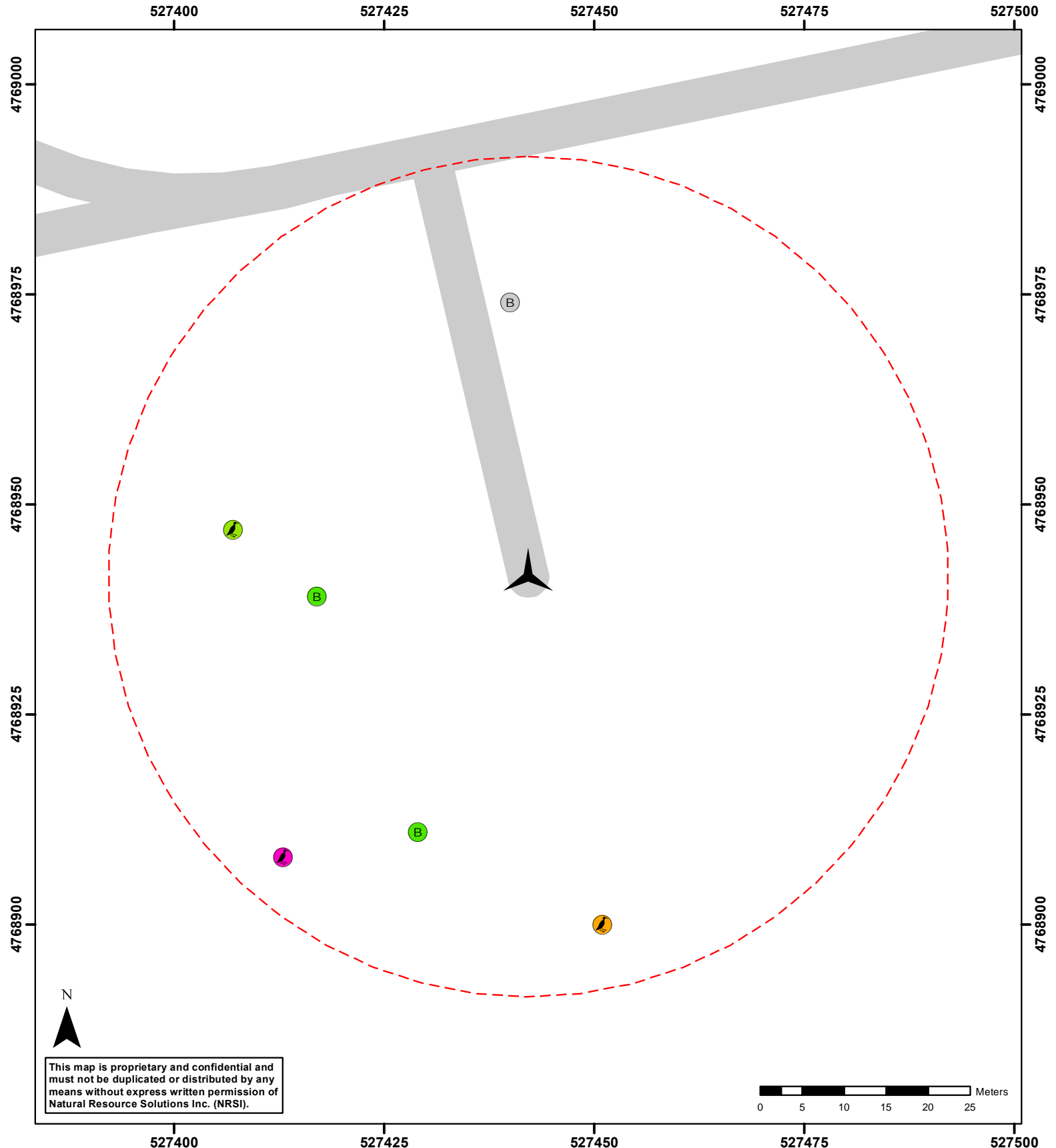
- Legend**
-  Turbine
 -  Search Radius (50m)
 -  Access Road

Appendix VI
Gunn's Hill WF
Turbine 08 Mortalities 2019

NAD83 - UTM Zone 17
 Scale: 1:600 (8.5x11")

Date: November 27, 2019
 Project: 1875C













This map is proprietary and confidential and must not be duplicated or distributed by any means without express written permission of Natural Resource Solutions Inc. (NRSI).



Legend


-  Turbine
-  Search Radius (50m)
-  Access Road
-  Hoary Bat
-  Silver-haired Bat
-  Golden-crowned Kinglet
-  Mourning Dove
-  Red-eyed Vireo

Appendix VI

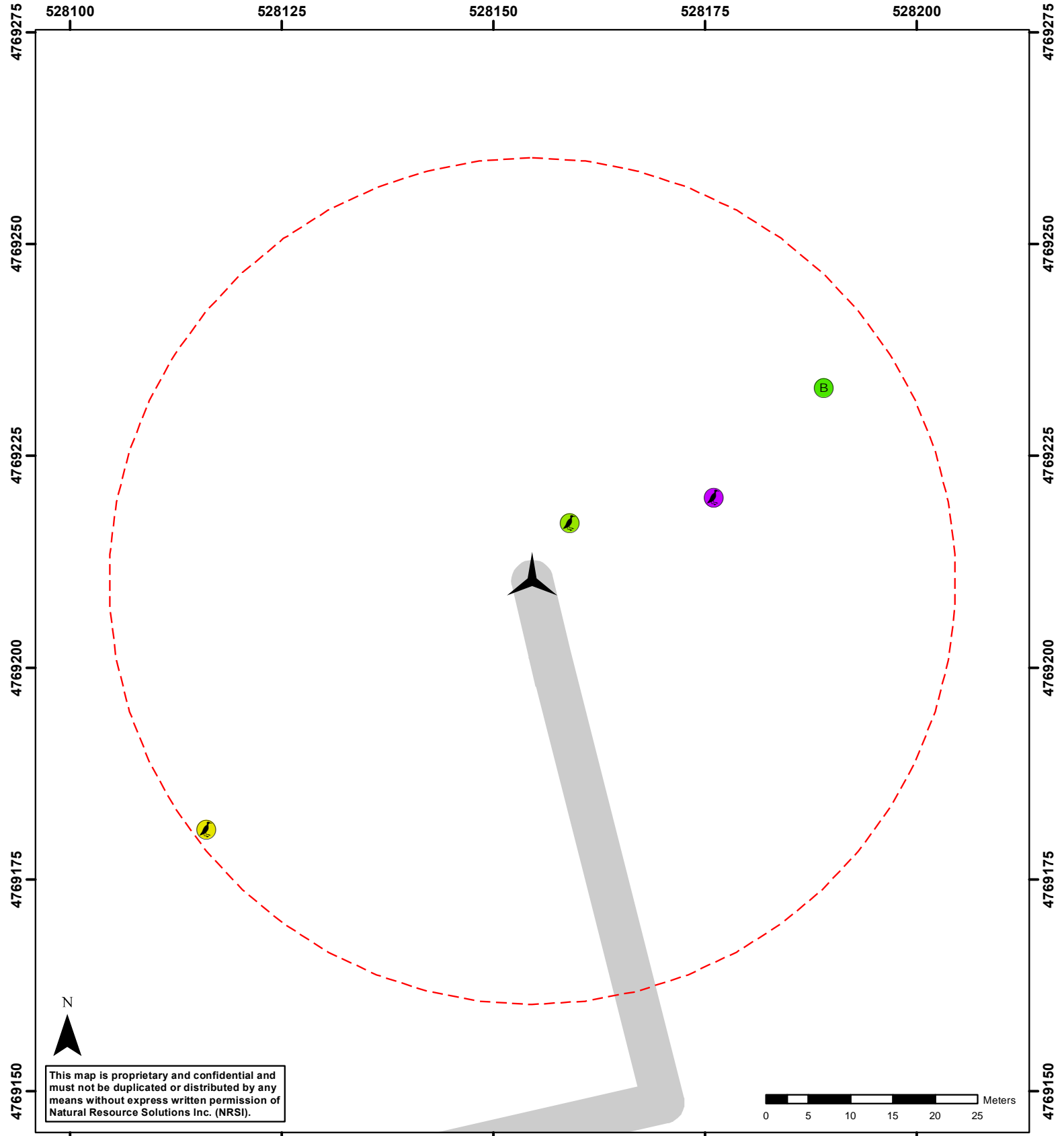
Gunn's Hill WF

Turbine 09 Mortalities 2019

NAD83 - UTM Zone 17 Scale: 1:600 (8.5x11")	Date: November 27, 2019 Project: 1875C
---	---








Aquatic, Terrestrial and Wetland Biologists



This map is proprietary and confidential and must not be duplicated or distributed by any means without express written permission of Natural Resource Solutions Inc. (NRSI).



Legend

-  Turbine
-  Hoary Bat
-  Red-eyed Vireo
-  Search Radius (50m)
-  Horned Lark
-  Access Road
-  House Wren


Appendix VI

Gunn's Hill WF

Turbine 10 Mortalities 2019

NAD83 - UTM Zone 17
Scale: 1:600 (8.5x11")

Date: November 27, 2019
Project: 1875C



Appendix VII
Visibility Class Mapping

Visibility Class Map

Project Name: Gunn's Hill WF Project #: 1875C Turbine #: T01 Degree of Slope 0 degrees Slope Orientation N/A (e.g. SSW)

Photo Numbers (from turbine base)
 Facing North: 1774
 Facing East: 1775
 Facing South: 1776
 Facing West: 1777
 (sketch habitat and visibility classes)

Date (DD/MM/YY): 07/05/19 ↑

Observer: Taylor V

Monthly/Seasonal Linear Transect Width: 5-7 m ↑

N

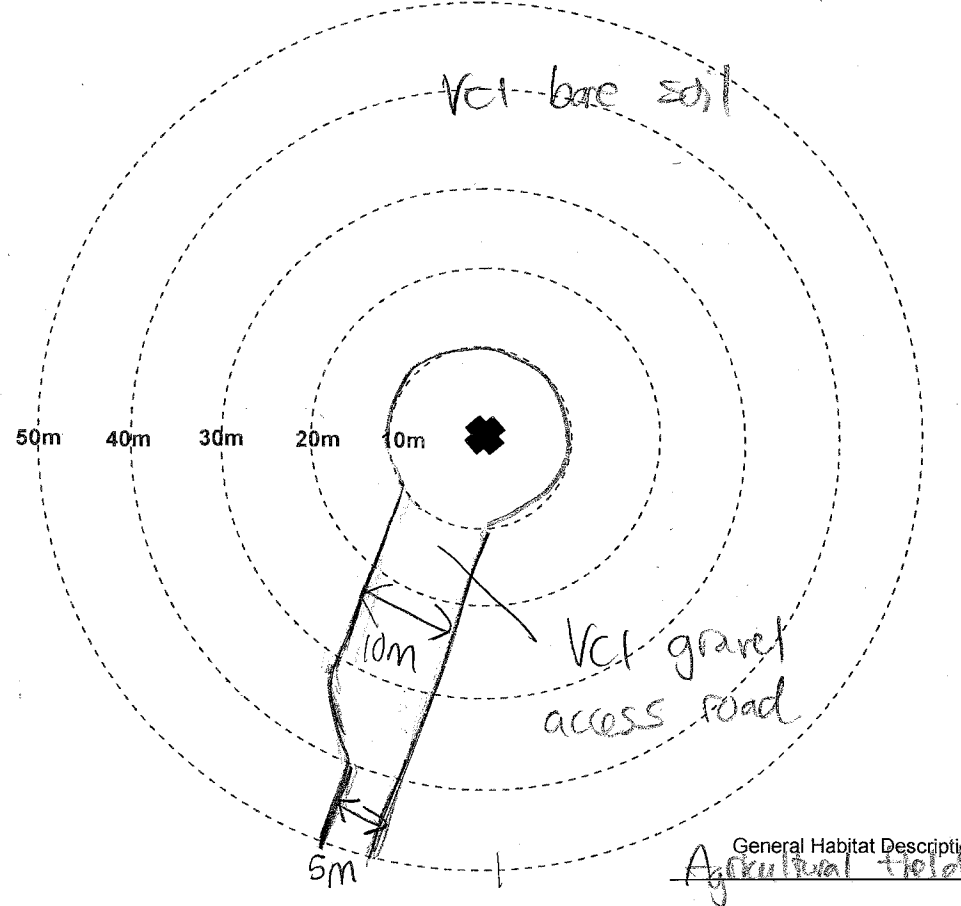
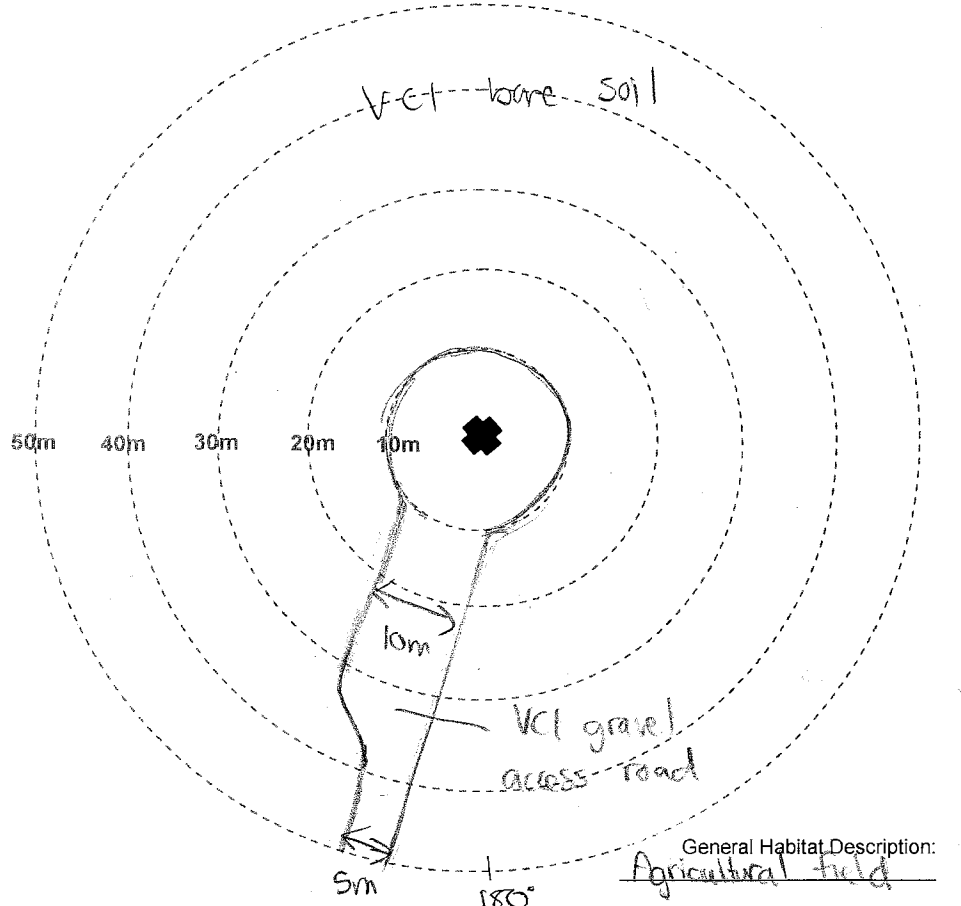
Photo Numbers (from turbine base)
 Facing North: 2055
 Facing East: 2056
 Facing South: 2057
 Facing West: 2058
 (sketch habitat and visibility classes)

Date (DD/MM/YY): 14/06/19 ↑

Observer: Taylor V

Monthly/Seasonal Linear Transect Width: 5-7 m ↑

N



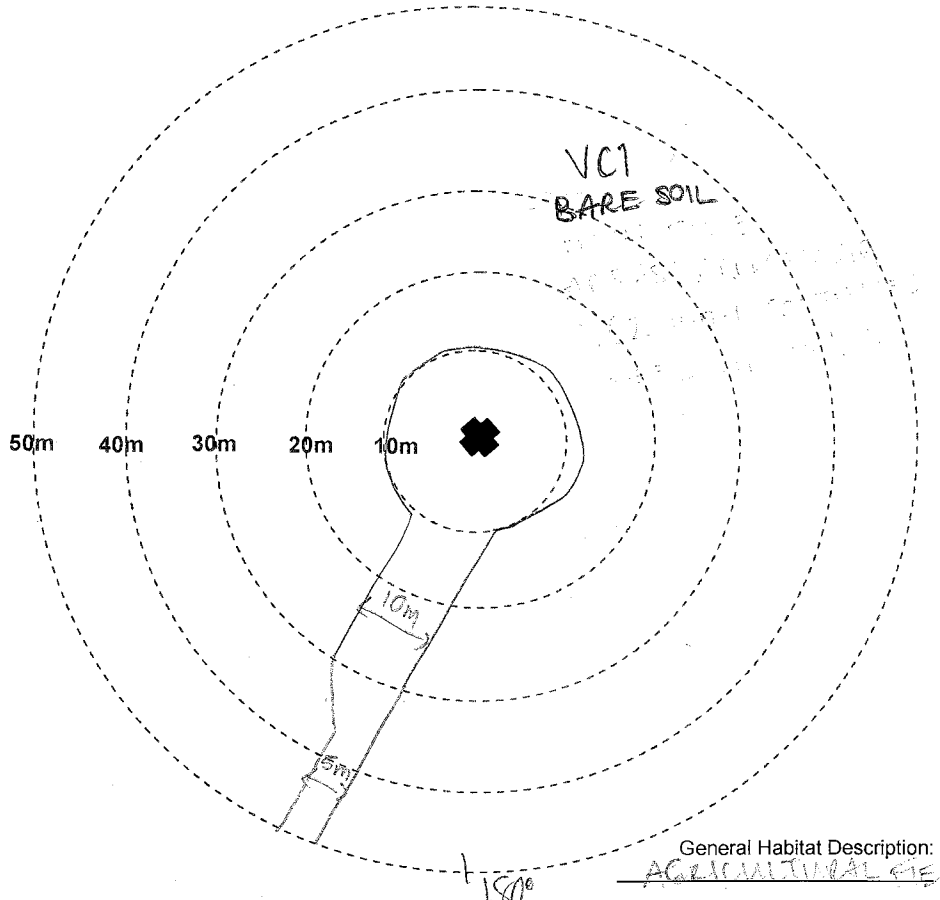
VISIBILITY CLASSES	
Class 1	≥ 90% bare ground; vegetation ≤ 15cm tall
Class 2	≥ 25% bare ground; vegetation ≤ 15cm tall
Class 3	≤ 25% bare ground; less than 25% of veg. > 30cm tall
Class 4	Little or no bare ground; more than 25% of veg. > 30cm tall
Not Searchable	Dense shrubs, woods, or other unsearchable habitats

Visibility Class Map

Project Name: QUINN'S HILL W.F. Project #: 1815C Turbine #: 701

Photo Numbers (from turbine base)
 Facing North: 3977
 Facing East: 3978
 Facing South: 3979
 Facing West: 3976
 (sketch habitat and visibility classes)

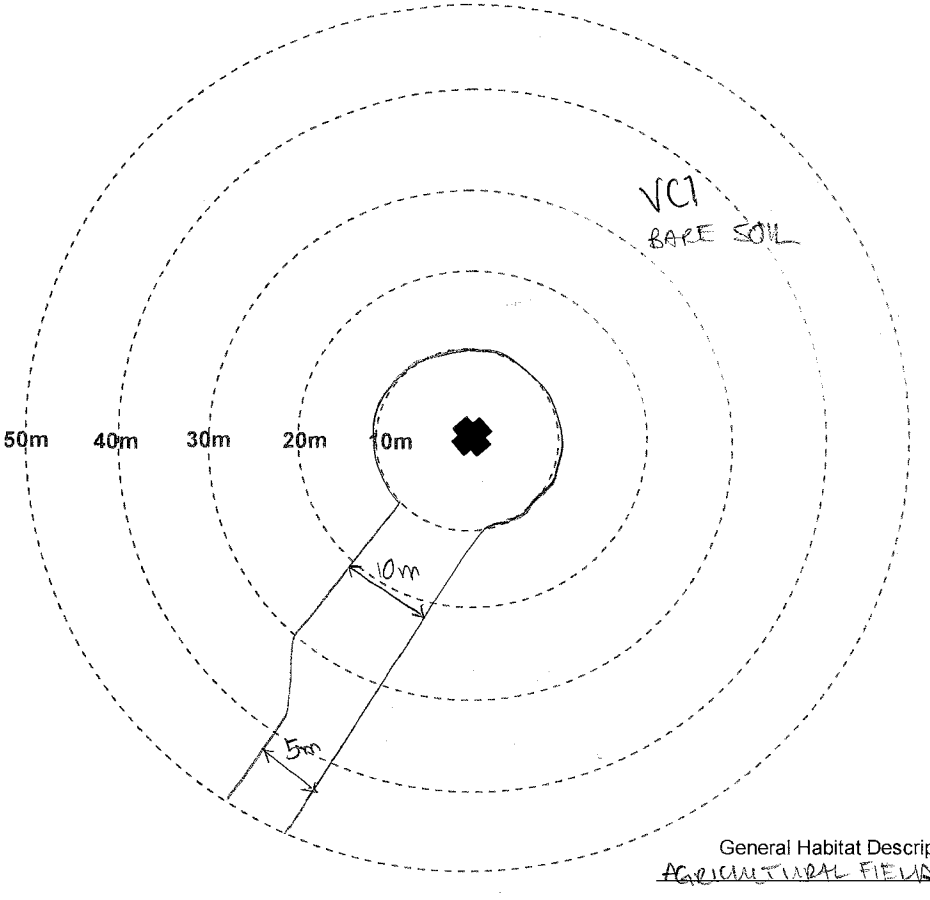
Date (DD/MM/YY): 05/07/19
 Observer: EMILY K.
 Monthly/Seasonal
 Linear Transect Width: 5-7 m



General Habitat Description:
AGRICULTURAL FIELD

Photo Numbers (from turbine base)
 Facing North: 4122
 Facing East: 4123
 Facing South: 4124
 Facing West: 4125
 (sketch habitat and visibility classes)

Date (DD/MM/YY): 09/08/19
 Observer: E.K.
 Monthly/Seasonal
 Linear Transect Width: 5-7 m



General Habitat Description:
AGRICULTURAL FIELD

VISIBILITY CLASSES	
Class 1	≥ 90% bare ground; vegetation ≤ 15cm tall
Class 2	≥ 25% bare ground; vegetation ≤ 15cm tall
Class 3	≤ 25% bare ground; less than 25% of veg. > 30cm tall
Class 4	Little or no bare ground; more than 25% of veg. > 30cm tall
Not Searchable	Dense shrubs, woods, or other unsearchable habitats

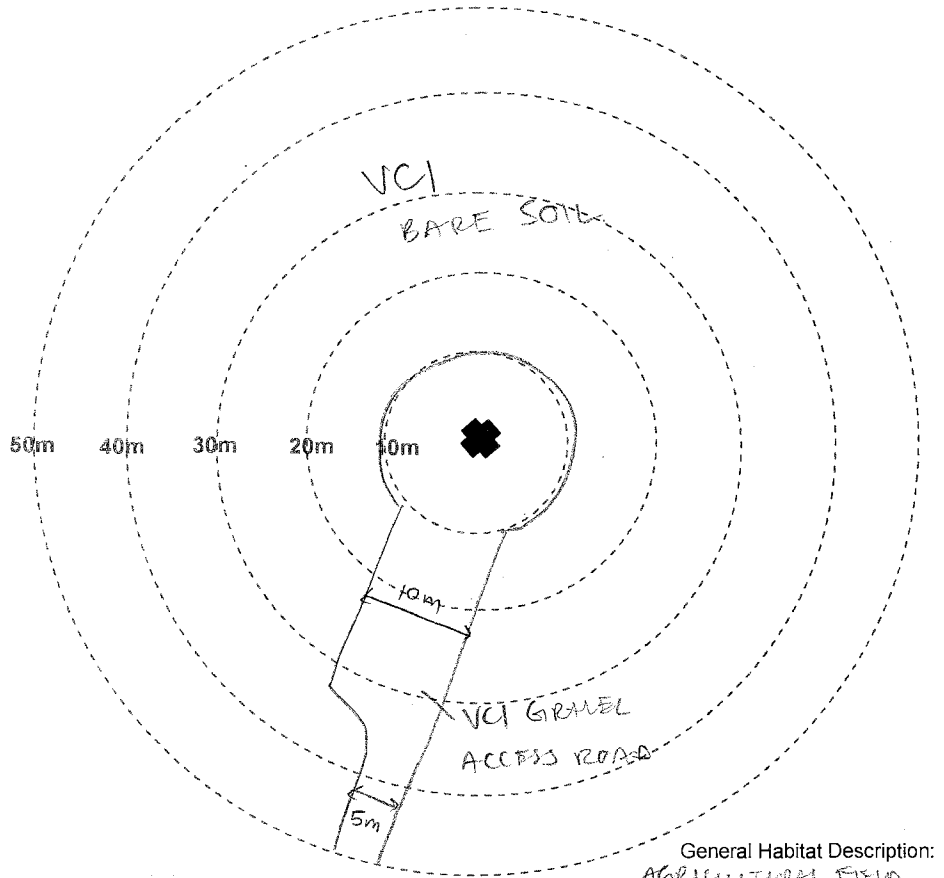
Visibility Class Map

Project Name: GUNN'S HILL WF.

Project #: 1875C Turbine #: T01

Photo Numbers (from turbine base)
 Facing North: 4195
 Facing East: 4196
 Facing South: 4197
 Facing West: 4198
 (sketch habitat and visibility classes)

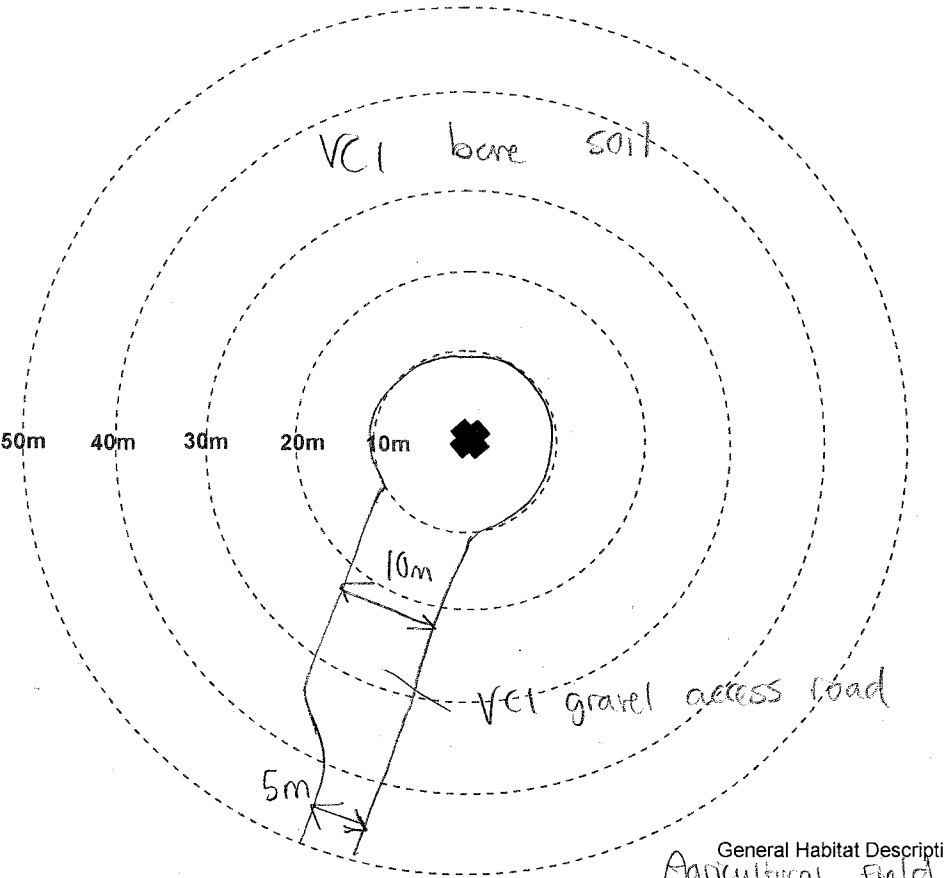
Date (DD/MM/YY): 06/09/19 ↑
 Observer: E.K.
 Monthly/Seasonal
 Linear Transect Width: 5-7 m ↑
N



General Habitat Description:
AGRICULTURAL FIELD

Photo Numbers (from turbine base)
 Facing North: 2491
 Facing East: 2492
 Facing South: 2493
 Facing West: 2494
 (sketch habitat and visibility classes)

Date (DD/MM/YY): 08/10/19 ↑
 Observer: Taylor V
 Monthly/Seasonal
 Linear Transect Width: 5-7 m ↑
N



General Habitat Description:
Agricultural Field

VISIBILITY CLASSES	
Class 1	≥ 90% bare ground; vegetation ≤ 15cm tall
Class 2	≥ 25% bare ground; vegetation ≤ 15cm tall
Class 3	≤ 25% bare ground; less than 25% of veg. > 30cm tall
Class 4	Little or no bare ground; more than 25% of veg. > 30cm tall
Not Searchable	Dense shrubs, woods, or other unsearchable habitats

Visibility Class Map

Project Name: Gunn's Hill WF Project #: 1875C Turbine #: T02 Degree of Slope 0 degrees Slope Orientation N/A (e.g. SSW)

Photo Numbers (from turbine base)
 Facing North: 1779
 Facing East: 1780
 Facing South: 1781
 Facing West: 1782
 (sketch habitat and visibility classes)

Date (DD/MM/YY): 07/05/19
 Observer: Taylor V
 Monthly/Seasonal Linear Transect Width: 5-7 m

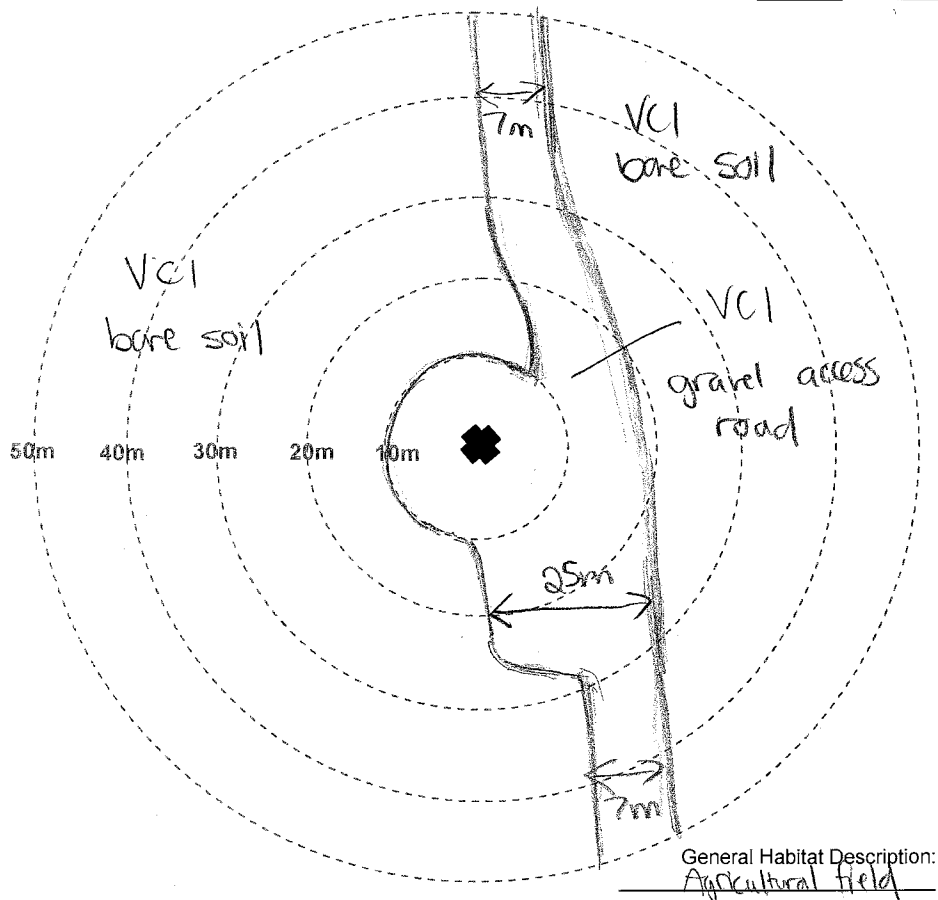
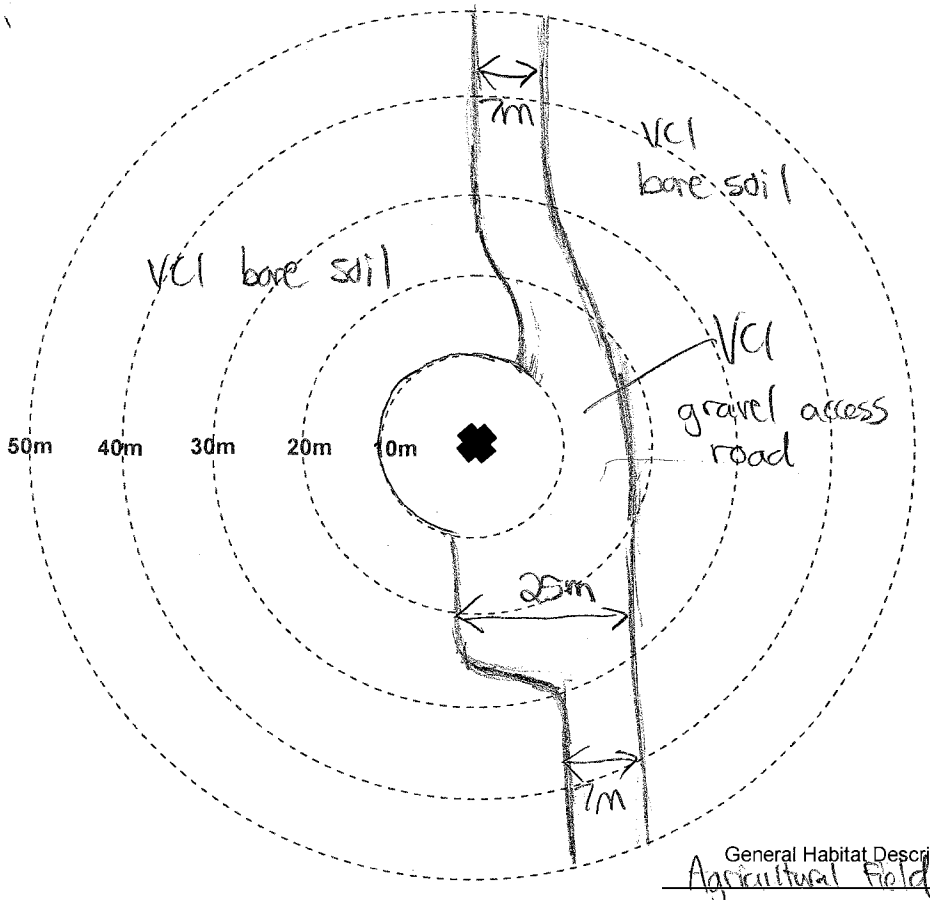


Photo Numbers (from turbine base)
 Facing North: 2009
 Facing East: 2010
 Facing South: 2011
 Facing West: 2012
 (sketch habitat and visibility classes)

Date (DD/MM/YY): 07/06/19
 Observer: Taylor V
 Monthly/Seasonal Linear Transect Width: 5-7 m



VISIBILITY CLASSES	
Class 1	≥ 90% bare ground; vegetation ≤ 15cm tall
Class 2	≥ 25% bare ground; vegetation ≤ 15cm tall
Class 3	≤ 25% bare ground; less than 25% of veg. > 30cm tall
Class 4	Little or no bare ground; more than 25% of veg. > 30cm tall
Not Searchable	Dense shrubs, woods, or other unsearchable habitats

Visibility Class Map

Project Name: GUNNYS HILL INF Project #: 1875C Turbine #: 302

Photo Numbers (from turbine base)
 Facing North: 2984
 Facing East: 2985
 Facing South: 2986
 Facing West: 2987
 (sketch habitat and visibility classes)

Date (DD/MM/YY): 05/07/19
 Observer: EMILY K.
 Monthly/Seasonal
 Linear Transect Width: 5-7 m

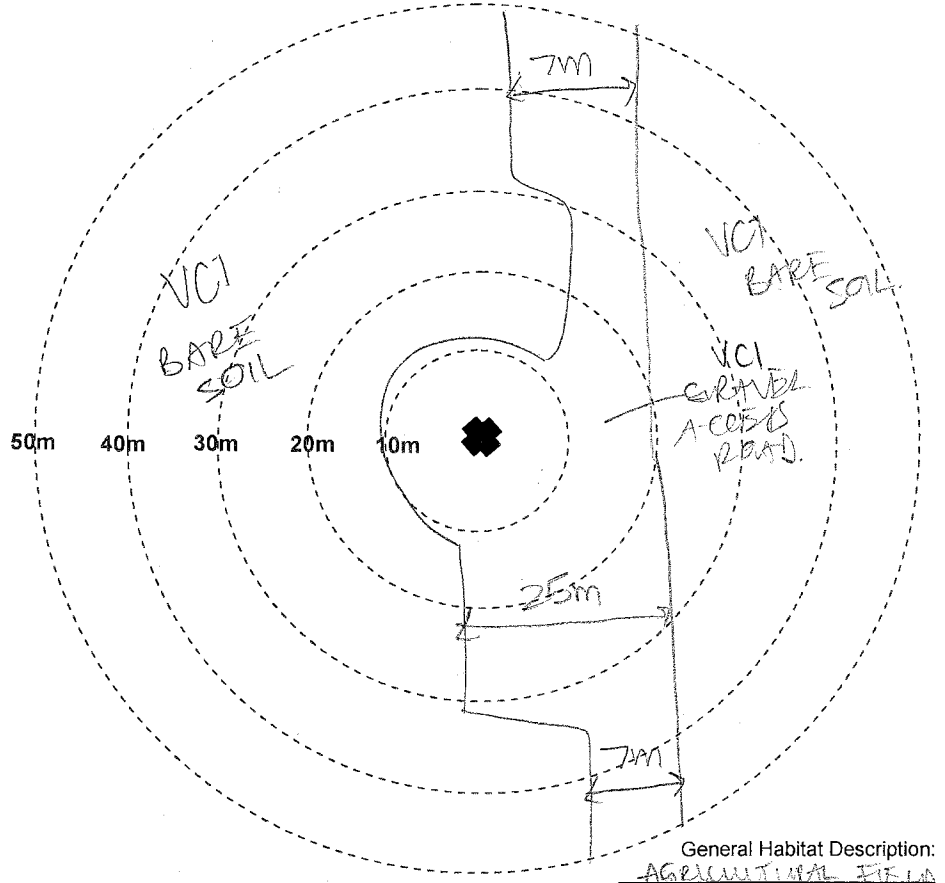
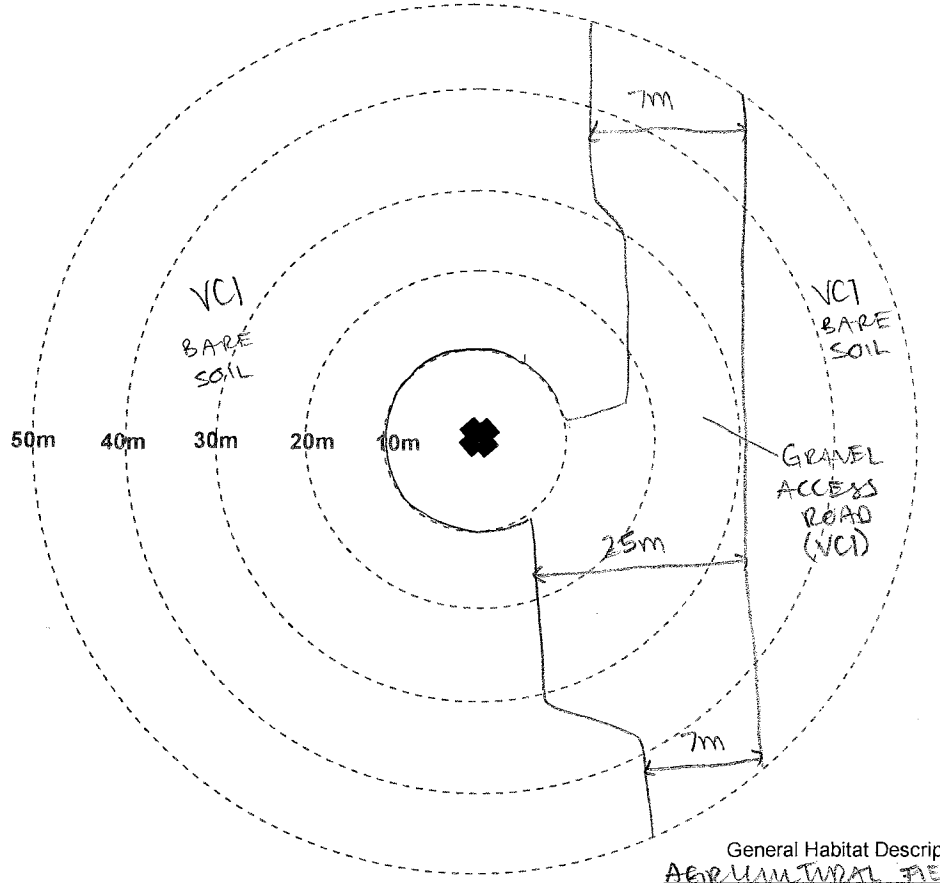


Photo Numbers (from turbine base)
 Facing North: 4127
 Facing East: 4128
 Facing South: 4129
 Facing West: 4130
 (sketch habitat and visibility classes)

Date (DD/MM/YY): 09/08/19
 Observer: EK
 Monthly/Seasonal
 Linear Transect Width: 5-7 m



VISIBILITY CLASSES	
Class 1	≥ 90% bare ground; vegetation ≤ 15cm tall
Class 2	≥ 25% bare ground; vegetation ≤ 15cm tall
Class 3	≤ 25% bare ground; less than 25% of veg. > 30cm tall
Class 4	Little or no bare ground; more than 25% of veg. > 30cm tall
Not Searchable	Dense shrubs, woods, or other unsearchable habitats

Visibility Class Map

Project Name: GIANN'S HILL WF Project #: 1875C Turbine #: T02

Photo Numbers (from turbine base)
 Facing North: 4199
 Facing East: 4200
 Facing South: 4201
 Facing West: 4202
 (sketch habitat and visibility classes)

Date (DD/MM/YY): 06/09/19
 Observer: EKL
 Monthly/Seasonal
 Linear Transect Width: 5-7 m

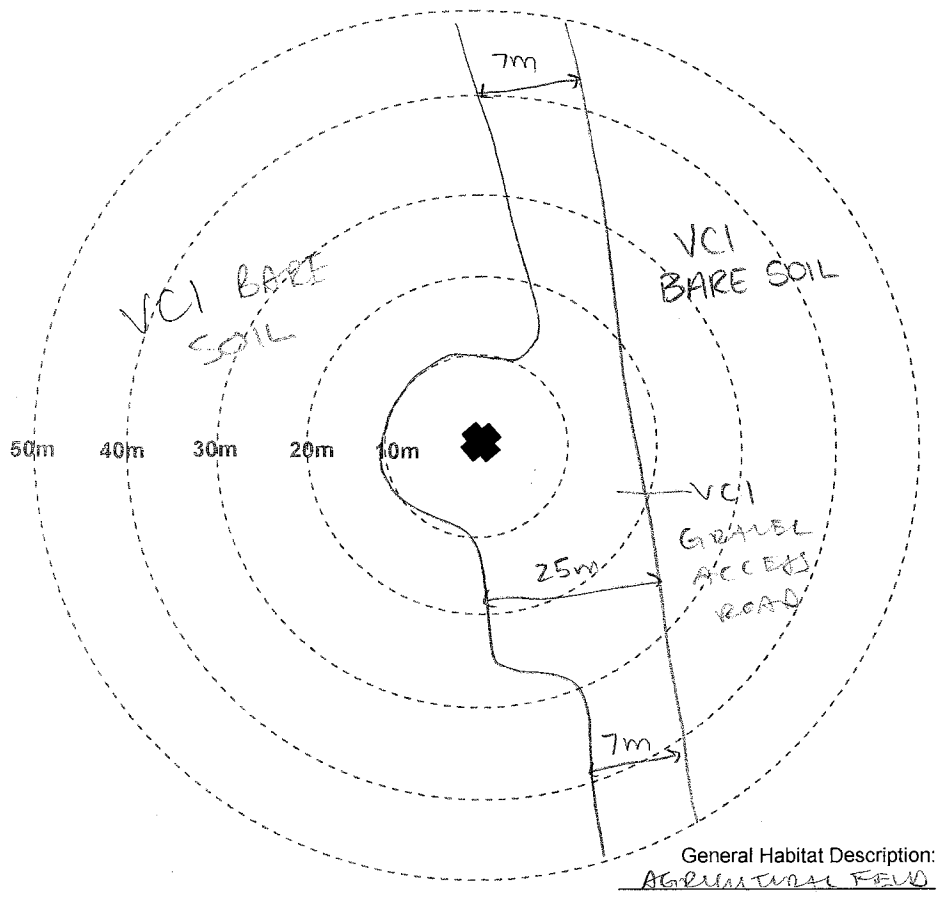
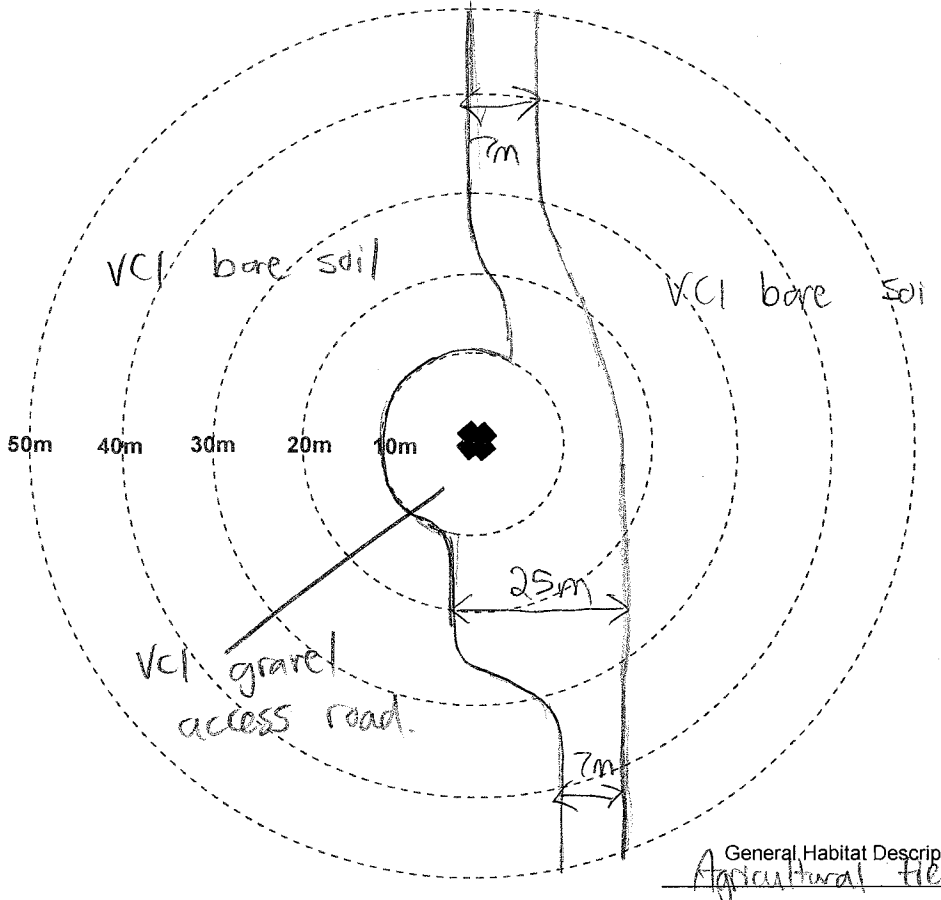


Photo Numbers (from turbine base)
 Facing North: 2437
 Facing East: 2438
 Facing South: 2439
 Facing West: 2440
 (sketch habitat and visibility classes)

Date (DD/MM/YY): 01/10/19
 Observer: Taylor V
 Monthly/Seasonal
 Linear Transect Width: 5-7 m



VISIBILITY CLASSES	
Class 1	≥ 90% bare ground; vegetation ≤ 15cm tall
Class 2	≥ 25% bare ground; vegetation ≤ 15cm tall
Class 3	≤ 25% bare ground; less than 25% of veg. > 30cm tall
Class 4	Little or no bare ground; more than 25% of veg. > 30cm tall
Not Searchable	Dense shrubs, woods, or other unsearchable habitats

Visibility Class Map

Project Name: Gunn's Hill WF Project #: 1875C Turbine #: T03 Degree of Slope 0 degrees Slope Orientation N/A (e.g. SSW)

Photo Numbers (from turbine base)
 Facing North: 1784
 Facing East: 1785
 Facing South: 1786
 Facing West: 1787
 (sketch habitat and visibility classes)

Date (DD/MM/YY): 07/05/19 ↑
 Observer: Taylor V
 Monthly/Seasonal Linear Transect Width: 5-7 m ↑
 N

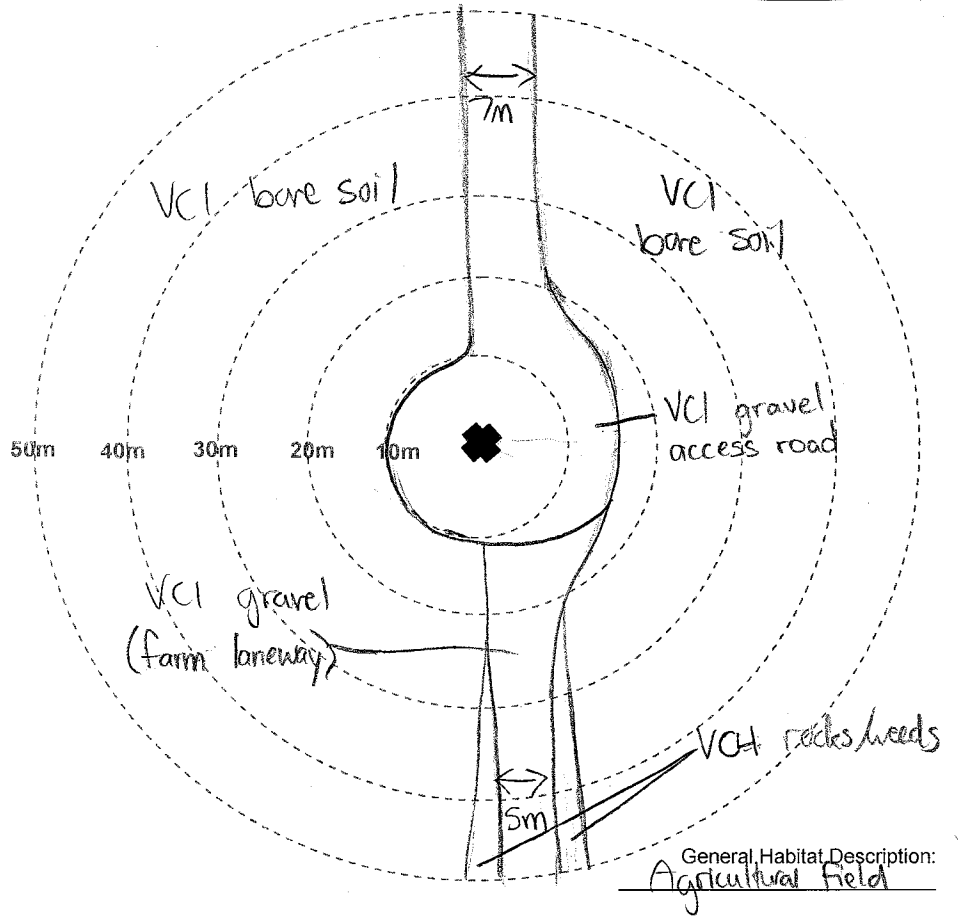
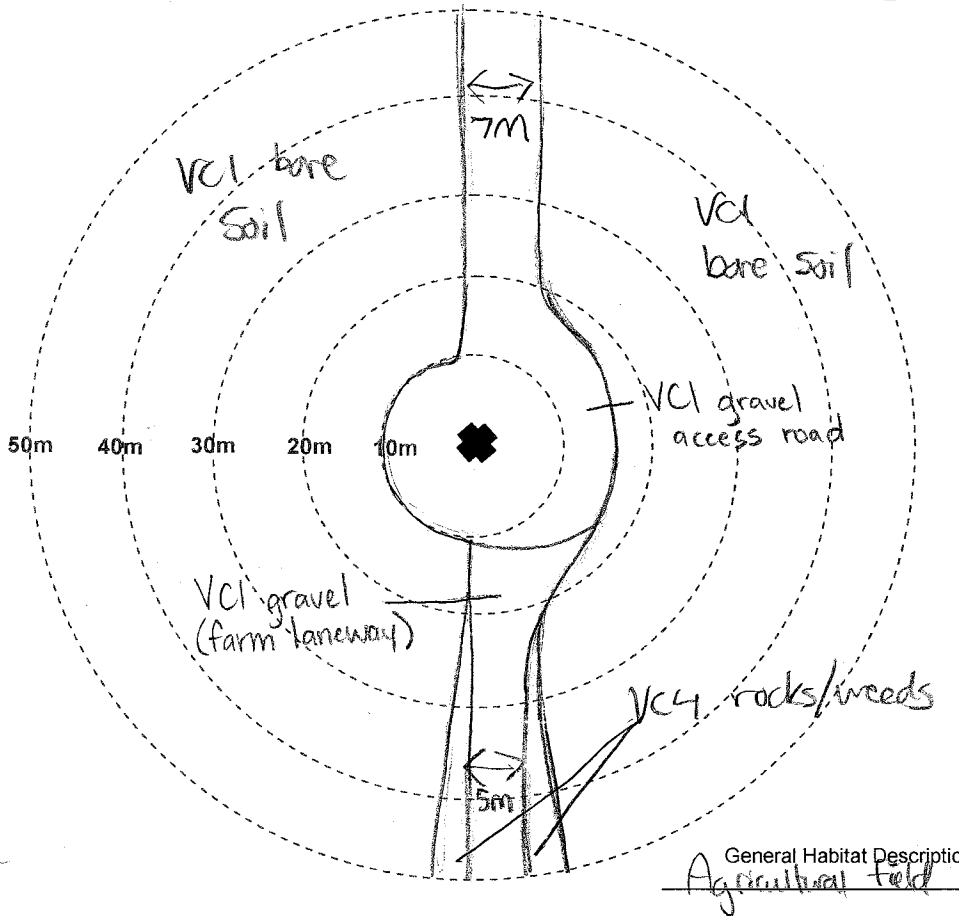


Photo Numbers (from turbine base)
 Facing North: 2013
 Facing East: 2014
 Facing South: 2015
 Facing West: 2016
 (sketch habitat and visibility classes)

Date (DD/MM/YY): 07/06/19 ↑
 Observer: Taylor V
 Monthly/Seasonal Linear Transect Width: 5-7 m ↑
 N



VISIBILITY CLASSES	
Class 1	≥ 90% bare ground; vegetation ≤ 15cm tall
Class 2	≥ 25% bare ground; vegetation ≤ 15cm tall
Class 3	≤ 25% bare ground; less than 25% of veg. > 30cm tall
Class 4	Little or no bare ground; more than 25% of veg. > 30cm tall
Not Searchable	Dense shrubs, woods, or other unsearchable habitats

Visibility Class Map

Project Name: CUNNYS HILL WFE Project #: 1815C Turbine #: T03

Photo Numbers (from turbine base)
 Facing North: 2988
 Facing East: 2989
 Facing South: 2990
 Facing West: 2991
 (sketch habitat and visibility classes)

Date (DD/MM/YY): 05/07/19
 Observer: EMILY K
 Monthly/Seasonal
 Linear Transect Width: 5-7 m

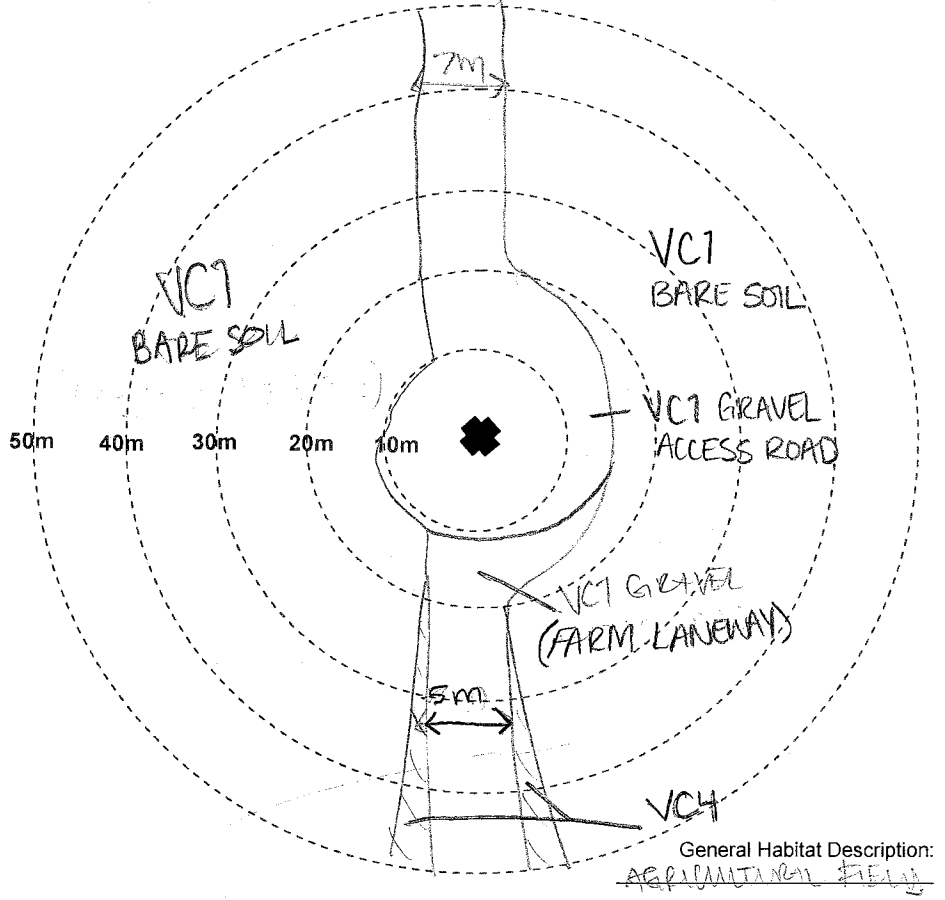
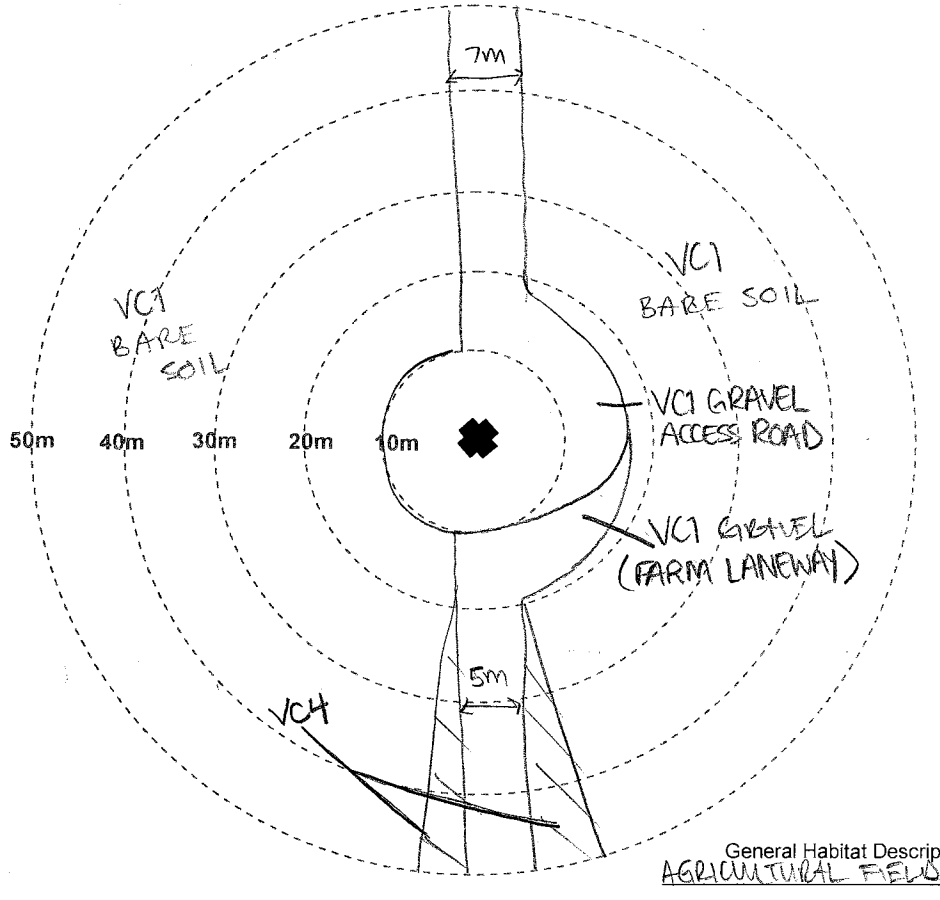


Photo Numbers (from turbine base)
 Facing North: 4131
 Facing East: 4132
 Facing South: 4133
 Facing West: 4134
 (sketch habitat and visibility classes)

Date (DD/MM/YY): 09/08/19
 Observer: EV
 Monthly/Seasonal
 Linear Transect Width: 5-7 m



VISIBILITY CLASSES	
Class 1	≥ 90% bare ground; vegetation ≤ 15cm tall
Class 2	≥ 25% bare ground; vegetation ≤ 15cm tall
Class 3	≤ 25% bare ground; less than 25% of veg. > 30cm tall
Class 4	Little or no bare ground; more than 25% of veg. > 30cm tall
Not Searchable	Dense shrubs, woods, or other unsearchable habitats

Visibility Class Map

Project Name: GUINN'S HILL WF. Project #: 18166 Turbine #: T03

Photo Numbers (from turbine base)
 Facing North: 4203
 Facing East: 4204
 Facing South: 4205
 Facing West: 4206
 (sketch habitat and visibility classes)

Date (DD/MM/YY): 06/09/19
 Observer: EV
 Monthly/Seasonal
 Linear Transect Width: 5-7 m

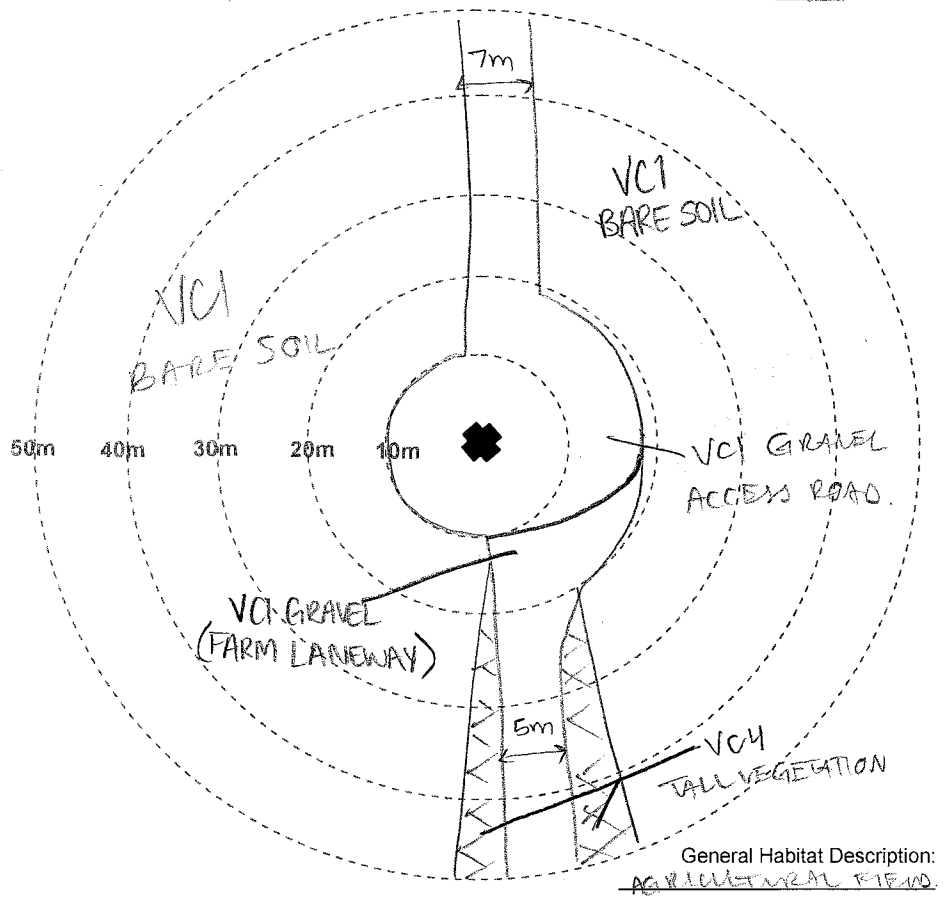
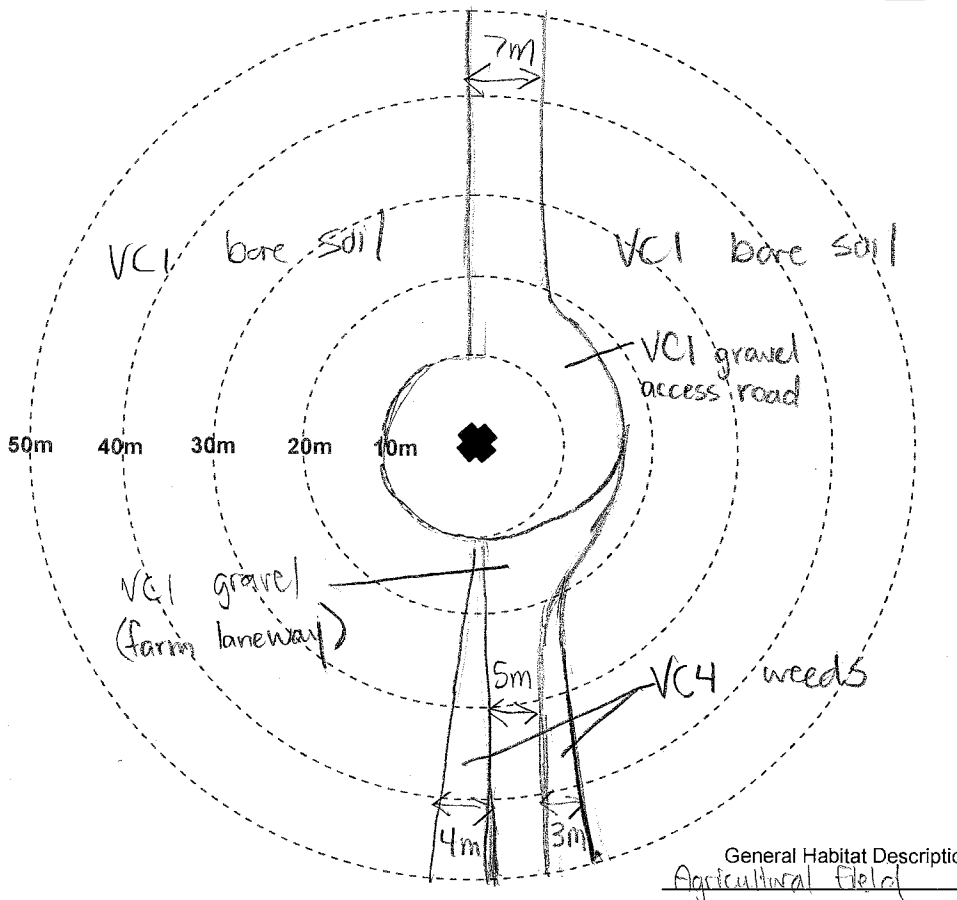


Photo Numbers (from turbine base)
 Facing North: 8407
 Facing East: 2428
 Facing South: 2429
 Facing West: 2430
 (sketch habitat and visibility classes)

Date (DD/MM/YY): 06/10/19
 Observer: Taylor V
 Monthly/Seasonal
 Linear Transect Width: 5-7 m



VISIBILITY CLASSES	
Class 1	≥ 90% bare ground; vegetation ≤ 15cm tall
Class 2	≥ 25% bare ground; vegetation ≤ 15cm tall
Class 3	≤ 25% bare ground; less than 25% of veg. > 30cm tall
Class 4	Little or no bare ground; more than 25% of veg. > 30cm tall
Not Searchable	Dense shrubs, woods, or other unsearchable habitats

Visibility Class Map

Project Name: Gunn's Hill WF

Project #: 1875C Turbine #: T04

Degree of Slope 2 degrees

Slope Orientation SE (e.g. SSW)

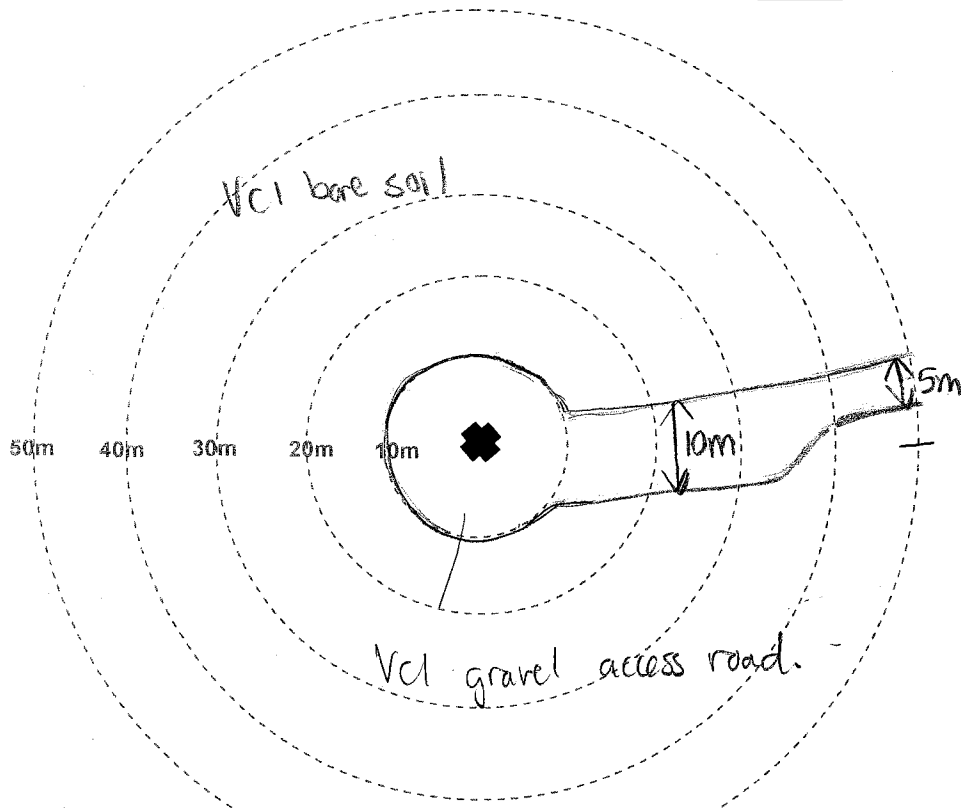
Photo Numbers (from turbine base)
 Facing North: 1796
 Facing East: 1797
 Facing South: 1798
 Facing West: 1799
 (sketch habitat and visibility classes)

Date (DD/MM/YY): 07/05/19
 Observer: Taylor V
 Monthly/Seasonal
 Linear Transect Width: 5-7 m

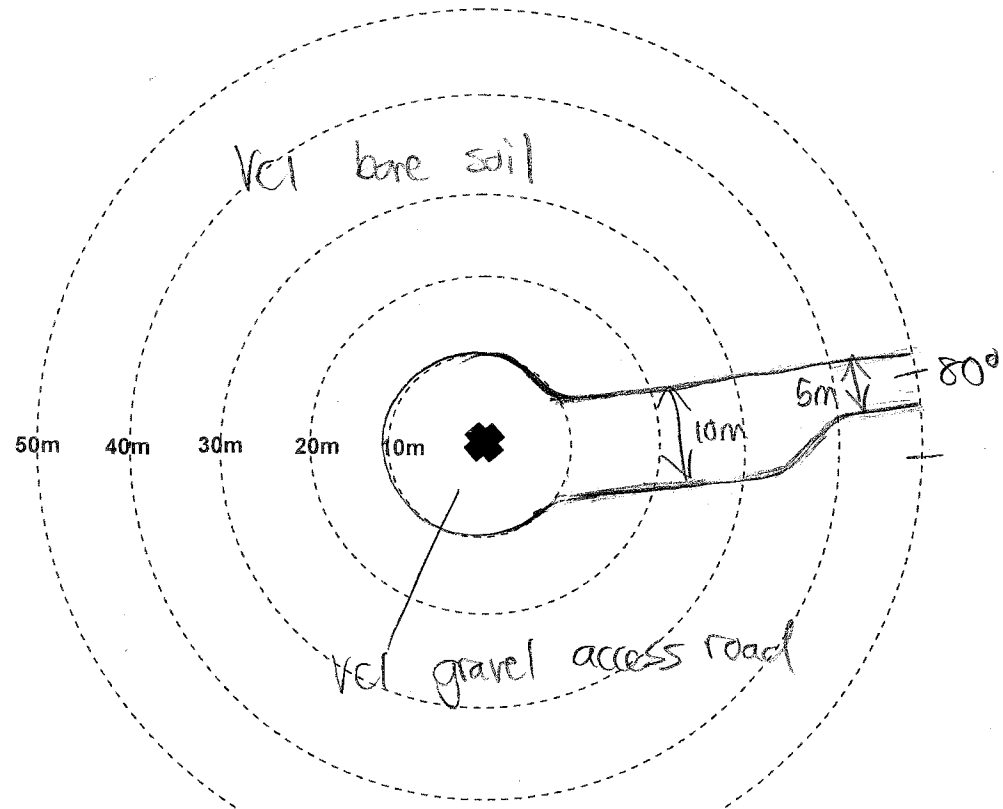


Photo Numbers (from turbine base)
 Facing North: 1943
 Facing East: 1944
 Facing South: 1945
 Facing West: 1946
 (sketch habitat and visibility classes)

Date (DD/MM/YY): 04/06/19
 Observer: Taylor V
 Monthly/Seasonal
 Linear Transect Width: 5-7 m



General Habitat Description:
Agricultural field



General Habitat Description:
Agricultural field

VISIBILITY CLASSES	
Class 1	≥ 90% bare ground; vegetation ≤ 15cm tall
Class 2	≥ 25% bare ground; vegetation ≤ 15cm tall
Class 3	≤ 25% bare ground; less than 25% of veg. > 30cm tall
Class 4	Little or no bare ground; more than 25% of veg. > 30cm tall
Not Searchable	Dense shrubs, woods, or other unsearchable habitats

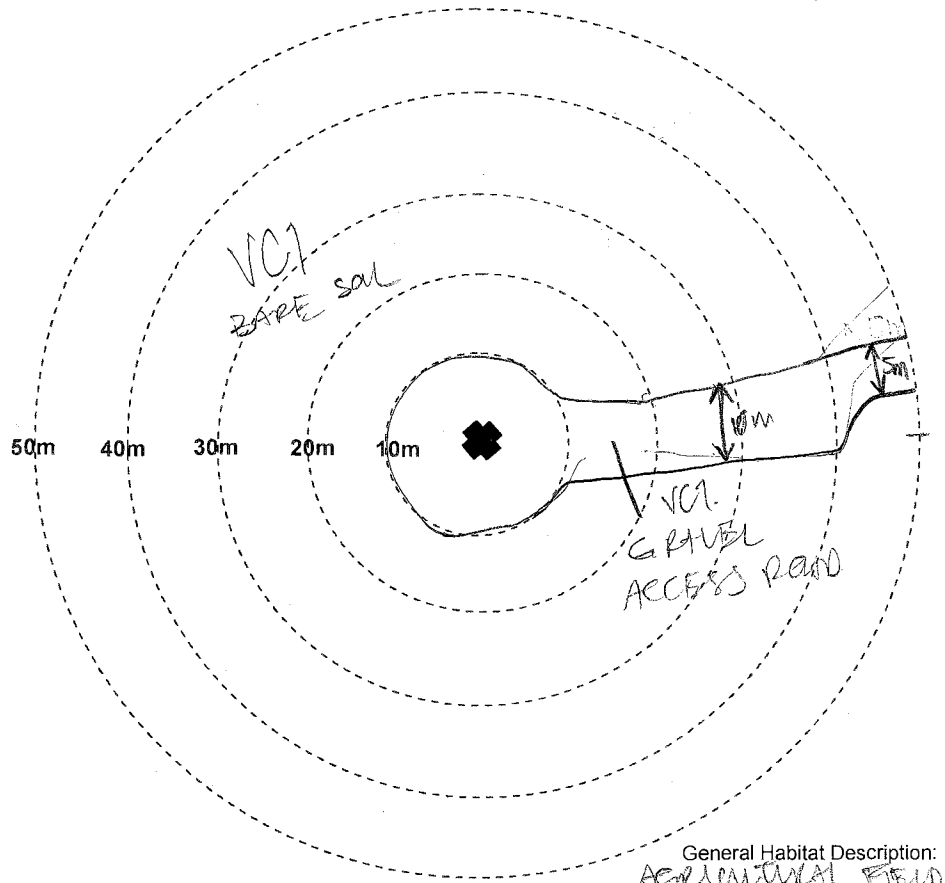
Visibility Class Map

Project Name: GLANN'S HILL WF

Project #: 1815C Turbine #: T04

Photo Numbers (from turbine base)
 Facing North: 2992
 Facing East: 2994
 Facing South: 2995
 Facing West: 2996
 (sketch habitat and visibility classes)

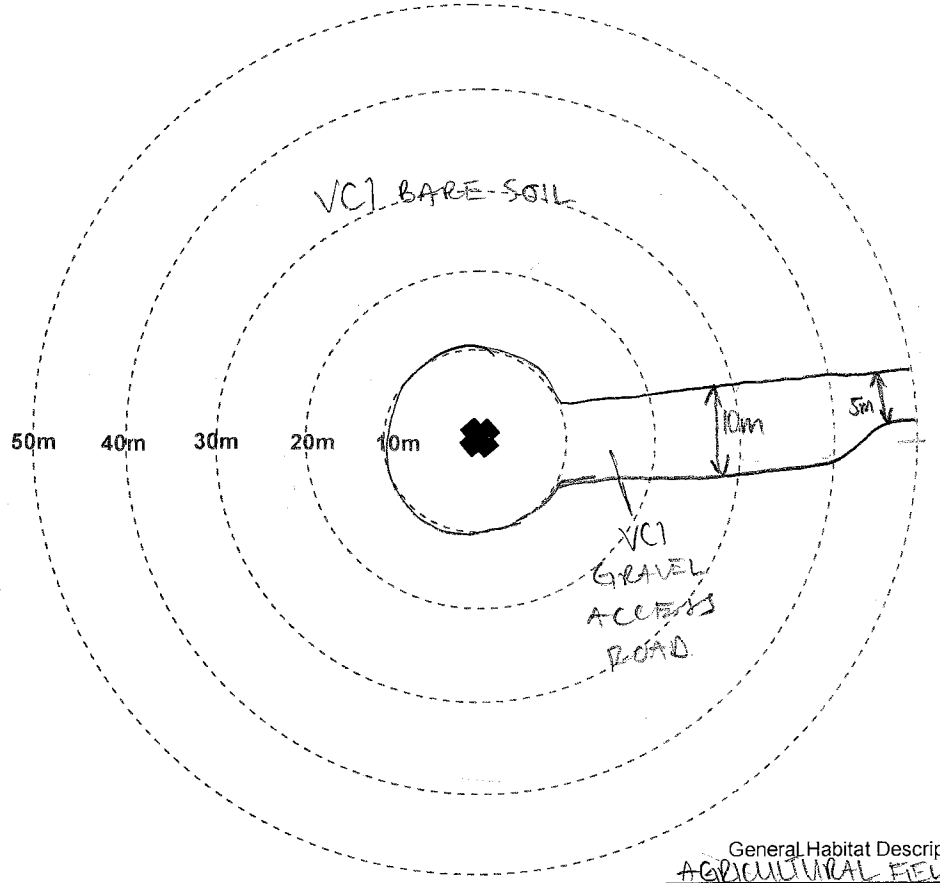
Date (DD/MM/YY): 05/07/19 ↑
 Observer: EMILY K
 Monthly/Seasonal
 Linear Transect Width: 5-7 m



General Habitat Description:
AGRICULTURAL FIELD

Photo Numbers (from turbine base)
 Facing North: 4135
 Facing East: 4136
 Facing South: 4137
 Facing West: 4138
 (sketch habitat and visibility classes)

Date (DD/MM/YY): 09/08/19 ↑
 Observer: EM
 Monthly/Seasonal
 Linear Transect Width: 5-7 m



General Habitat Description:
AGRICULTURAL FIELD

VISIBILITY CLASSES	
Class 1	≥ 90% bare ground; vegetation ≤ 15cm tall
Class 2	≥ 25% bare ground; vegetation ≤ 15cm tall
Class 3	≤ 25% bare ground; less than 25% of veg. > 30cm tall
Class 4	Little or no bare ground; more than 25% of veg. > 30cm tall
Not Searchable	Dense shrubs, woods, or other unsearchable habitats

Visibility Class Map

Project Name: GILMAN'S HILL WF. Project #: 1875C Turbine #: T04

Photo Numbers (from turbine base)
 Facing North: 4212
 Facing East: 4214
 Facing South: 4215
 Facing West: 4216
 (sketch habitat and visibility classes)

Date (DD/MM/YY): 06/09/19
 Observer: E.K.
 Monthly/Seasonal
 Linear Transect Width: 5-7 m

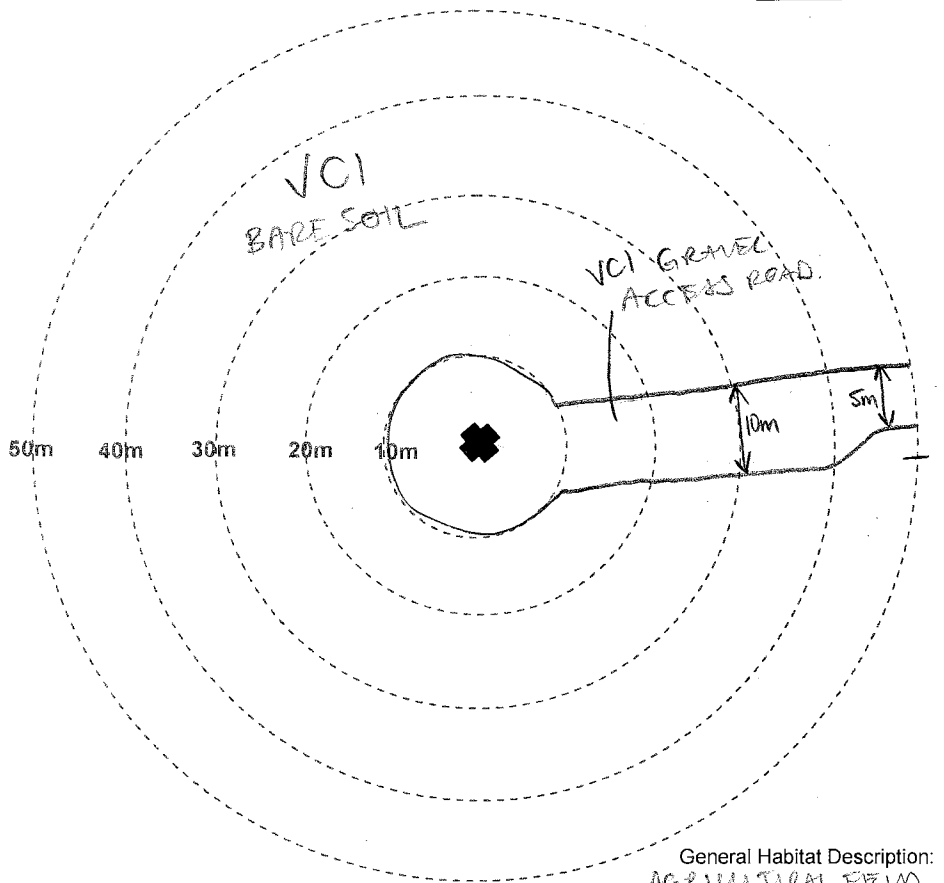
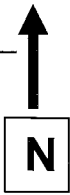
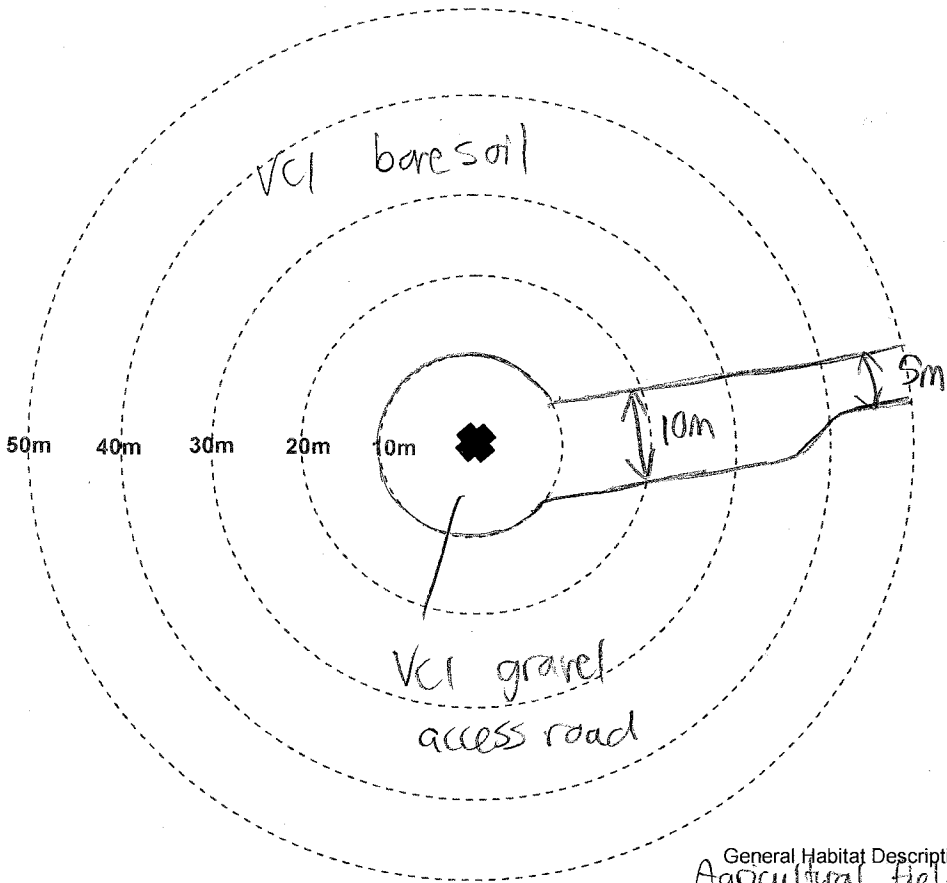


Photo Numbers (from turbine base)
 Facing North: 2448
 Facing East: 2449
 Facing South: 2450
 Facing West: 2451
 (sketch habitat and visibility classes)

Date (DD/MM/YY): 04/10/19
 Observer: Taylor V
 Monthly/Seasonal
 Linear Transect Width: 5-7 m



VISIBILITY CLASSES	
Class 1	≥ 90% bare ground; vegetation ≤ 15cm tall
Class 2	≥ 25% bare ground; vegetation ≤ 15cm tall
Class 3	≤ 25% bare ground; less than 25% of veg. > 30cm tall
Class 4	Little or no bare ground; more than 25% of veg. > 30cm tall
Not Searchable	Dense shrubs, woods, or other unsearchable habitats

Visibility Class Map

Project Name: Gunn's Hill WF Project #: 1875C Turbine #: T05 Degree of Slope 2 degrees Slope Orientation S (e.g. SSW)

Photo Numbers (from turbine base)
 Facing North: 1847
 Facing East: 1848
 Facing South: 1849
 Facing West: 1850
 (sketch habitat and visibility classes)

Date (DD/MM/YY): 10/09/19
 Observer: Taylor V
 Monthly/Seasonal
 Linear Transect Width: 5-7 m

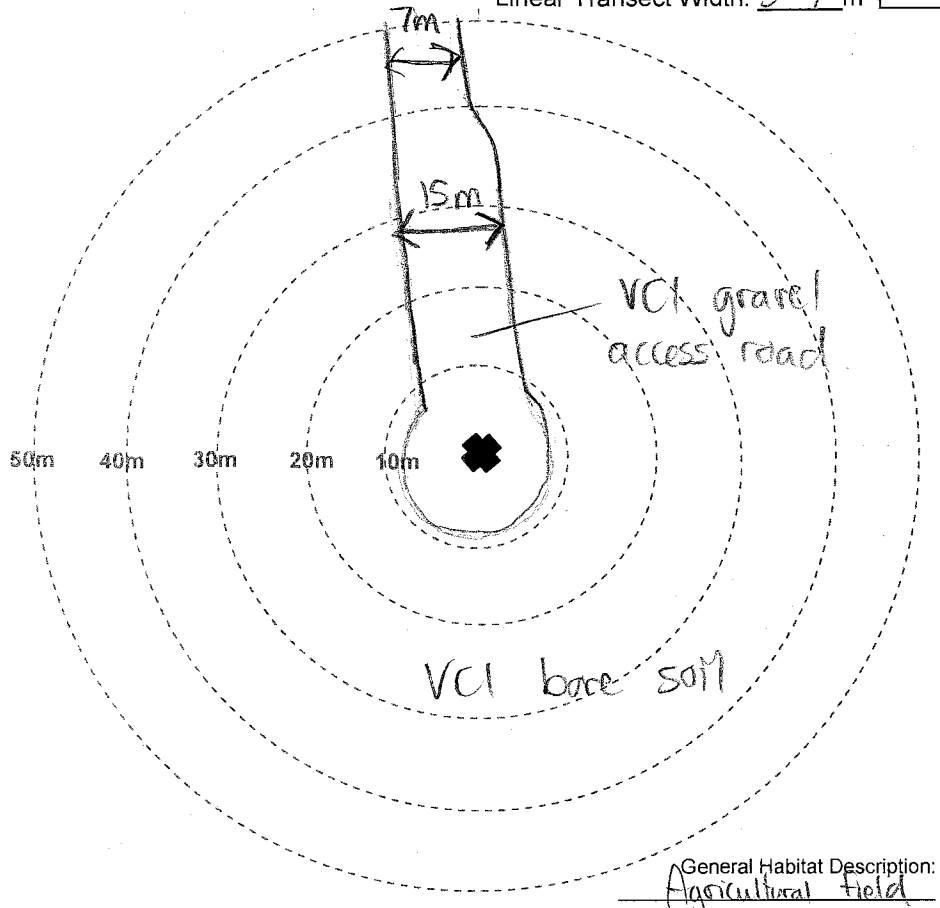
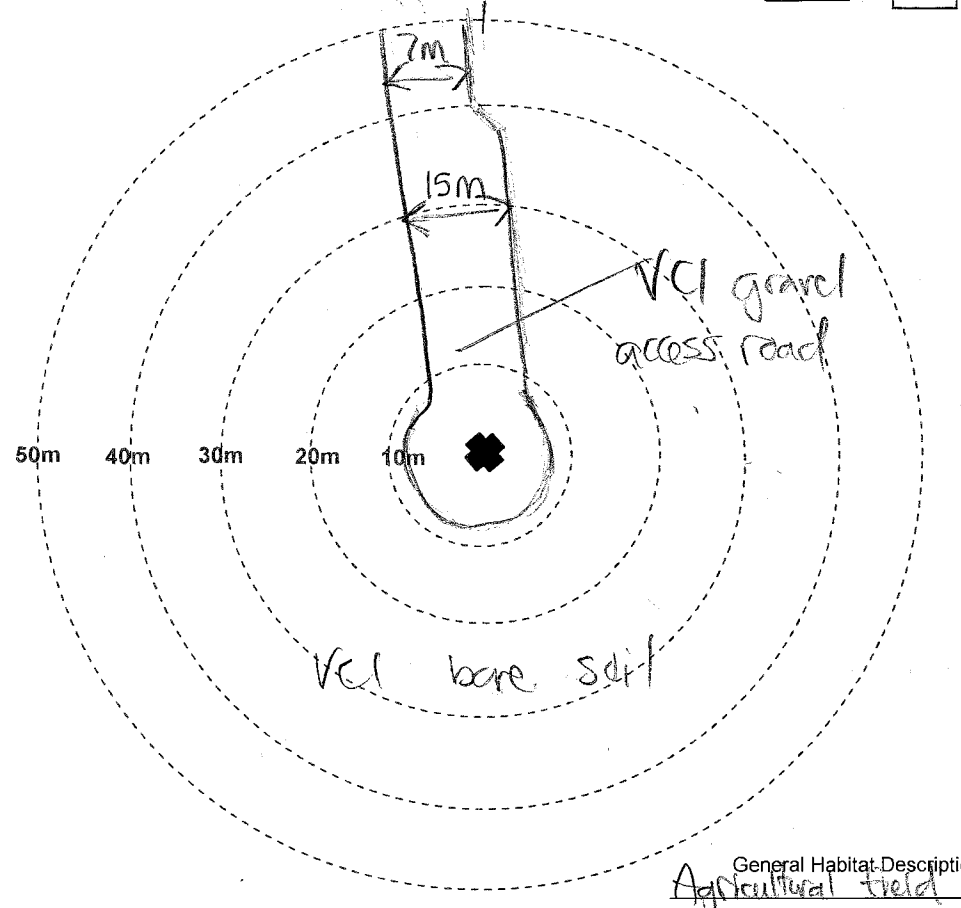


Photo Numbers (from turbine base)
 Facing North: 1947
 Facing East: 1948
 Facing South: 1949
 Facing West: 1950
 (sketch habitat and visibility classes)

Date (DD/MM/YY): 04/06/19
 Observer: Taylor V
 Monthly/Seasonal
 Linear Transect Width: 5-7 m



VISIBILITY CLASSES	
Class 1	≥ 90% bare ground; vegetation ≤ 15cm tall
Class 2	≥ 25% bare ground; vegetation ≤ 15cm tall
Class 3	≤ 25% bare ground; less than 25% of veg. > 30cm tall
Class 4	Little or no bare ground; more than 25% of veg. > 30cm tall
Not Searchable	Dense shrubs, woods, or other unsearchable habitats

Visibility Class Map

Project Name: GUNNS HILL WFE

Project #: 1815C Turbine #: T05

Photo Numbers (from turbine base)
 Facing North: 3998
 Facing East: 3999
 Facing South: 4000
 Facing West: 4001
 (sketch habitat and visibility classes)

Date (DD/MM/YY): 05/07/19

Observer: EMILY K

Monthly/Seasonal
 Linear Transect Width: 57 m

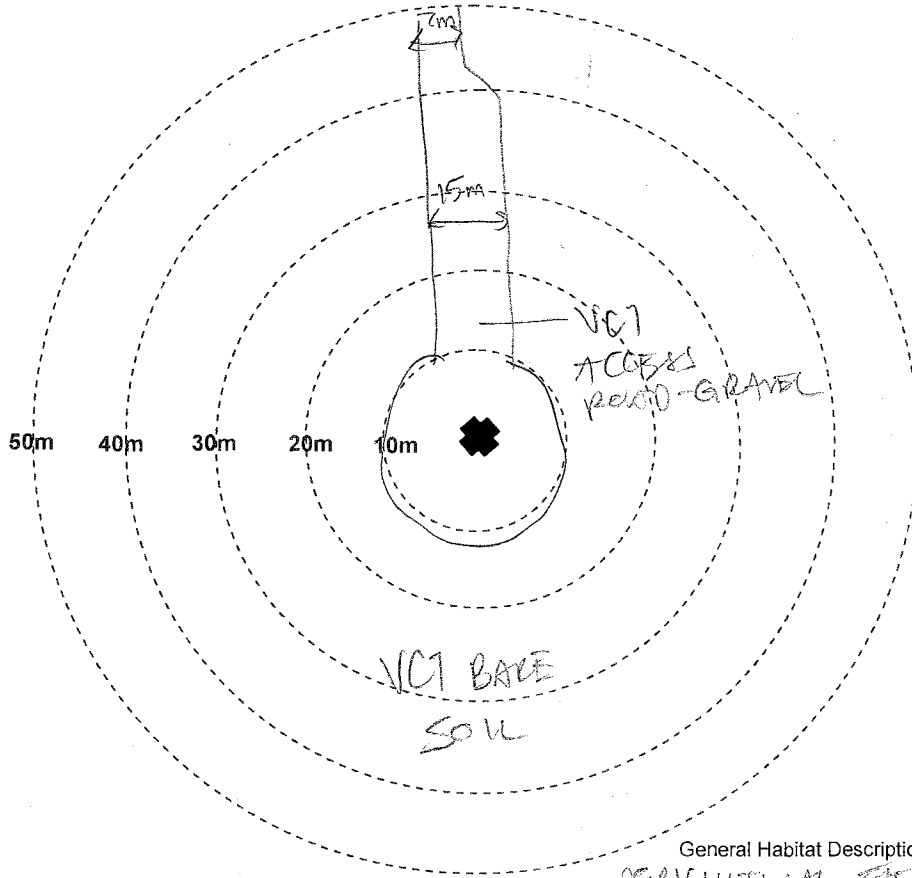
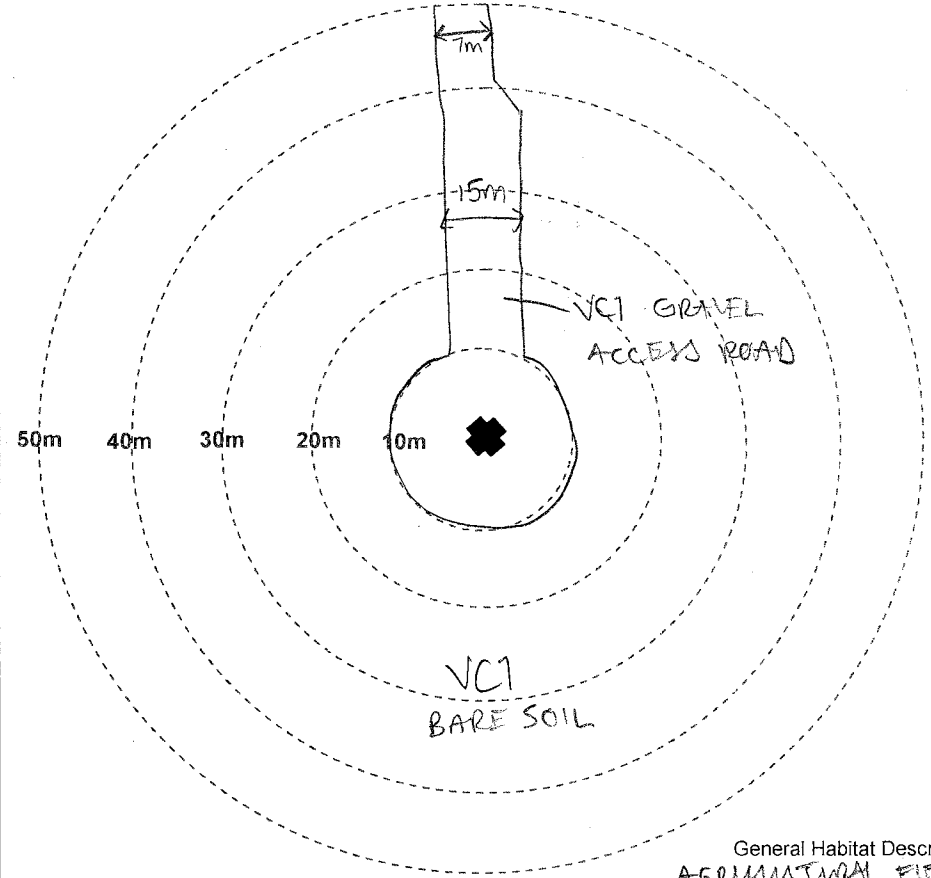


Photo Numbers (from turbine base)
 Facing North: 4142
 Facing East: 4143
 Facing South: 4144
 Facing West: 4145
 (sketch habitat and visibility classes)

Date (DD/MM/YY): 09/08/19

Observer: SK

Monthly/Seasonal
 Linear Transect Width: 57 m



VISIBILITY CLASSES	
Class 1	≥ 90% bare ground; vegetation ≤ 15cm tall
Class 2	≥ 25% bare ground; vegetation ≤ 15cm tall
Class 3	≤ 25% bare ground; less than 25% of veg. > 30cm tall
Class 4	Little or no bare ground; more than 25% of veg. > 30cm tall
Not Searchable	Dense shrubs, woods, or other unsearchable habitats

Visibility Class Map

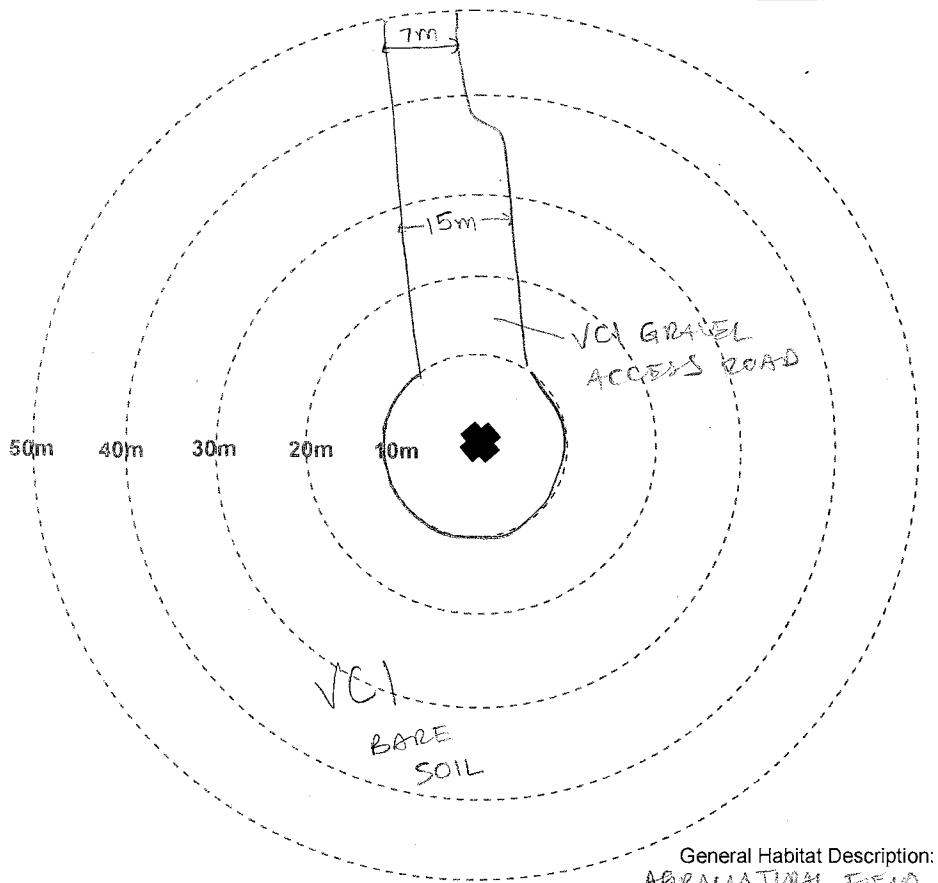
Project Name: CARMIN'S HILL WF

Project #: 1879

Turbine #: TC5

Photo Numbers (from turbine base)
 Facing North: 0217
 Facing East: 0218
 Facing South: 0219
 Facing West: 0220
 (sketch habitat and visibility classes)

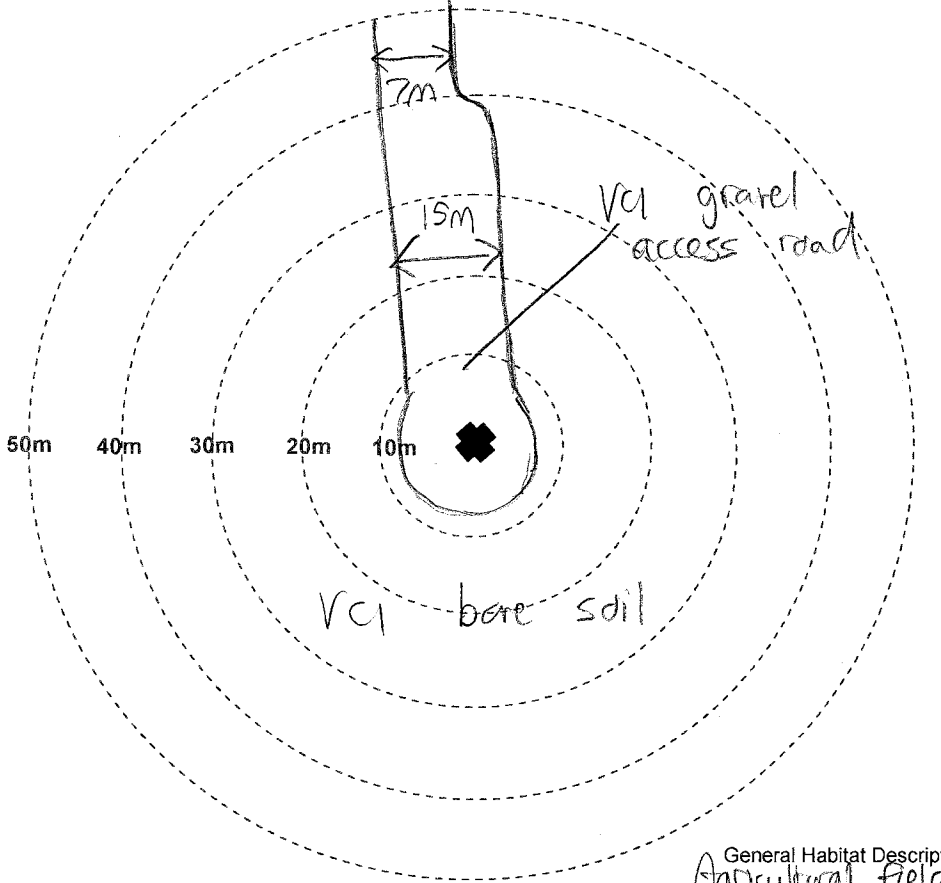
Date (DD/MM/YY): 06/09/19
 Observer: E.K.
 Monthly/Seasonal
 Linear Transect Width: 5-7 m



General Habitat Description:
AGRICULTURAL FIELD

Photo Numbers (from turbine base)
 Facing North: 2452
 Facing East: 2453
 Facing South: 2454
 Facing West: 2455
 (sketch habitat and visibility classes)

Date (DD/MM/YY): 04/10/19
 Observer: Taylor V
 Monthly/Seasonal
 Linear Transect Width: 5-7 m



General Habitat Description:
Agricultural field

VISIBILITY CLASSES	
Class 1	≥ 90% bare ground; vegetation ≤ 15cm tall
Class 2	≥ 25% bare ground; vegetation ≤ 15cm tall
Class 3	≤ 25% bare ground; less than 25% of veg. > 30cm tall
Class 4	Little or no bare ground; more than 25% of veg. > 30cm tall
Not Searchable	Dense shrubs, woods, or other unsearchable habitats

Visibility Class Map

Project Name: Gunn's Hill WF Project #: 1875C Turbine #: T06 Degree of Slope 2 degrees Slope Orientation NE (e.g. SSW)

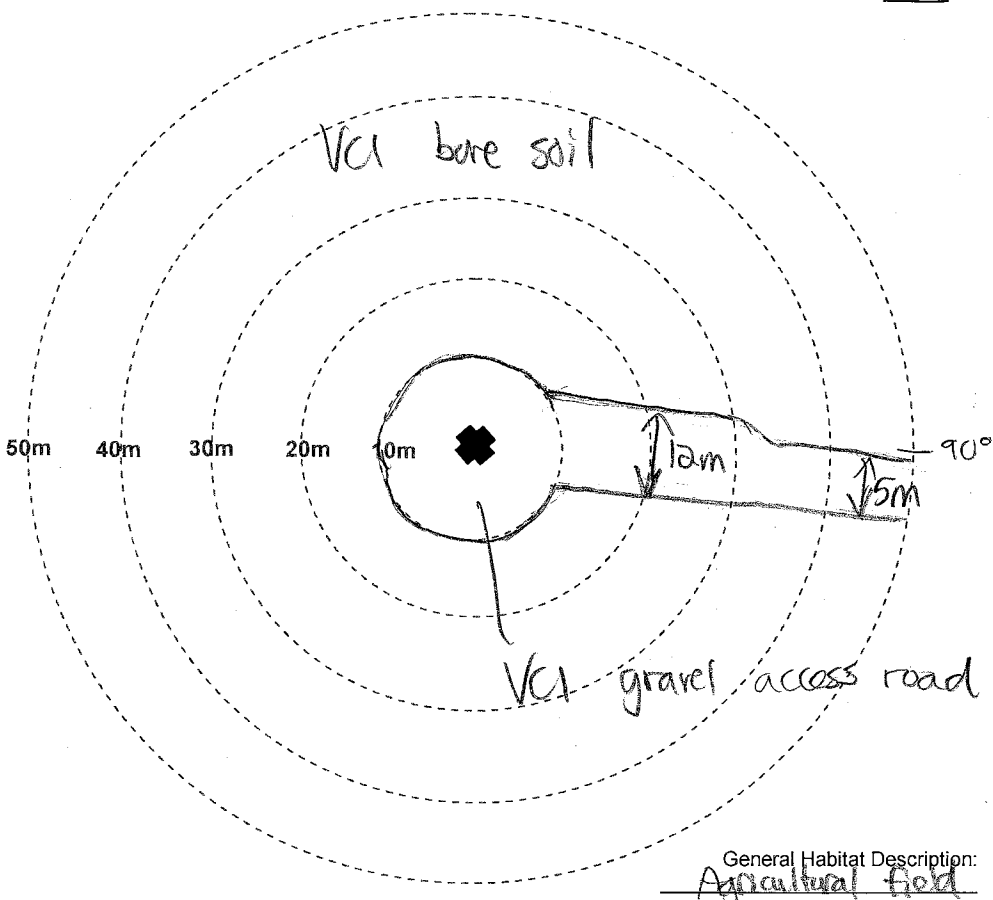
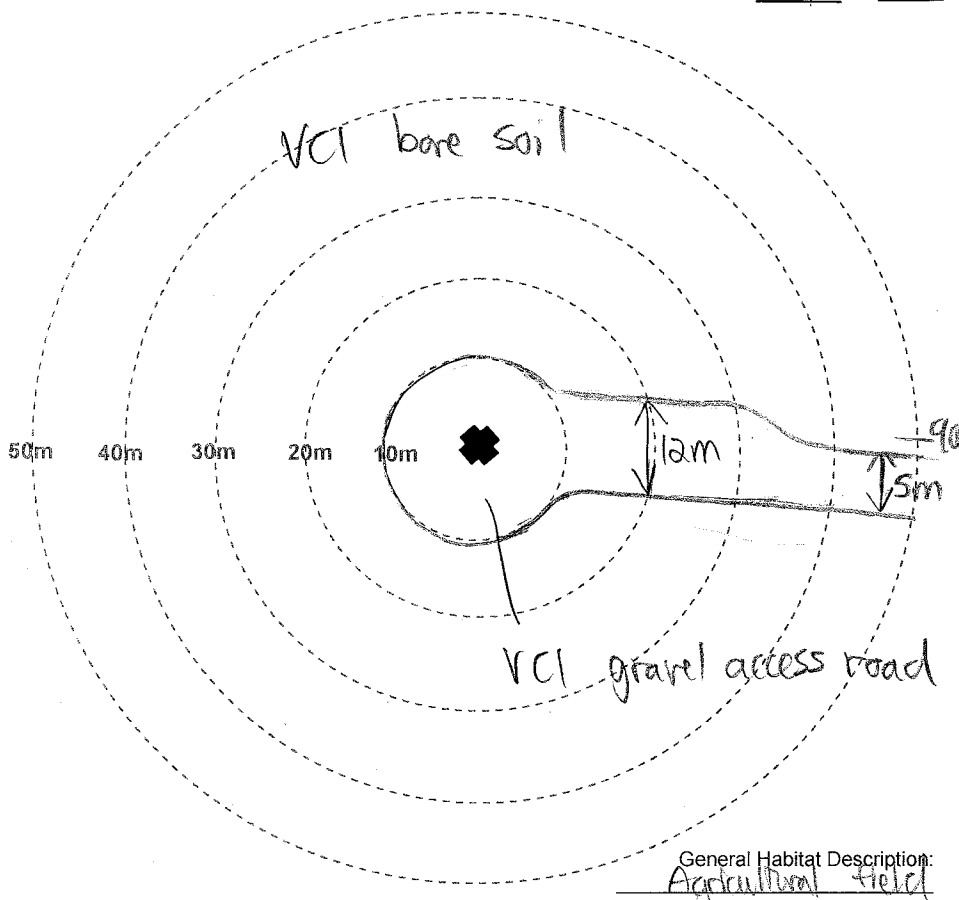
Photo Numbers (from turbine base)
 Facing North: 1788
 Facing East: 1789
 Facing South: 1790
 Facing West: 1791
 (sketch habitat and visibility classes)

Date (DD/MM/YY): 07/05/19
 Observer: Taylor V
 Monthly/Seasonal
 Linear Transect Width: 5-7 m



Photo Numbers (from turbine base)
 Facing North: 2018
 Facing East: 2019
 Facing South: 2020
 Facing West: 2021
 (sketch habitat and visibility classes)

Date (DD/MM/YY): 07/06/19
 Observer: Taylor V
 Monthly/Seasonal
 Linear Transect Width: 5-7 m



VISIBILITY CLASSES	
Class 1	≥ 90% bare ground; vegetation ≤ 15cm tall
Class 2	≥ 25% bare ground; vegetation ≤ 15cm tall
Class 3	≤ 25% bare ground; less than 25% of veg. > 30cm tall
Class 4	Little or no bare ground; more than 25% of veg. > 30cm tall
Not Searchable	Dense shrubs, woods, or other unsearchable habitats

Visibility Class Map

Project Name: CANNING HILL WF

Project #: 1866 Turbine #: 106

Photo Numbers (from turbine base)
 Facing North: 11022
 Facing East: 11023
 Facing South: 11024
 Facing West: 11025
 (sketch habitat and visibility classes)

Date (DD/MM/YY): 11/07/19
 Observer: EK
 Monthly/Seasonal
 Linear Transect Width: 5-7 m

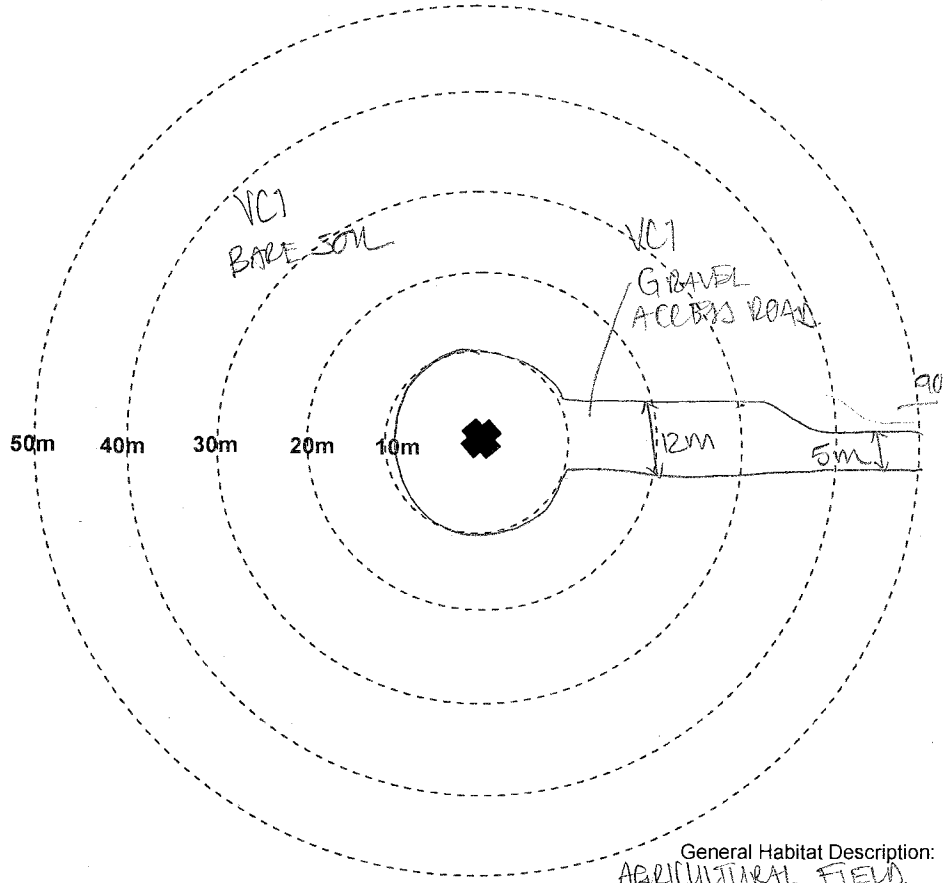
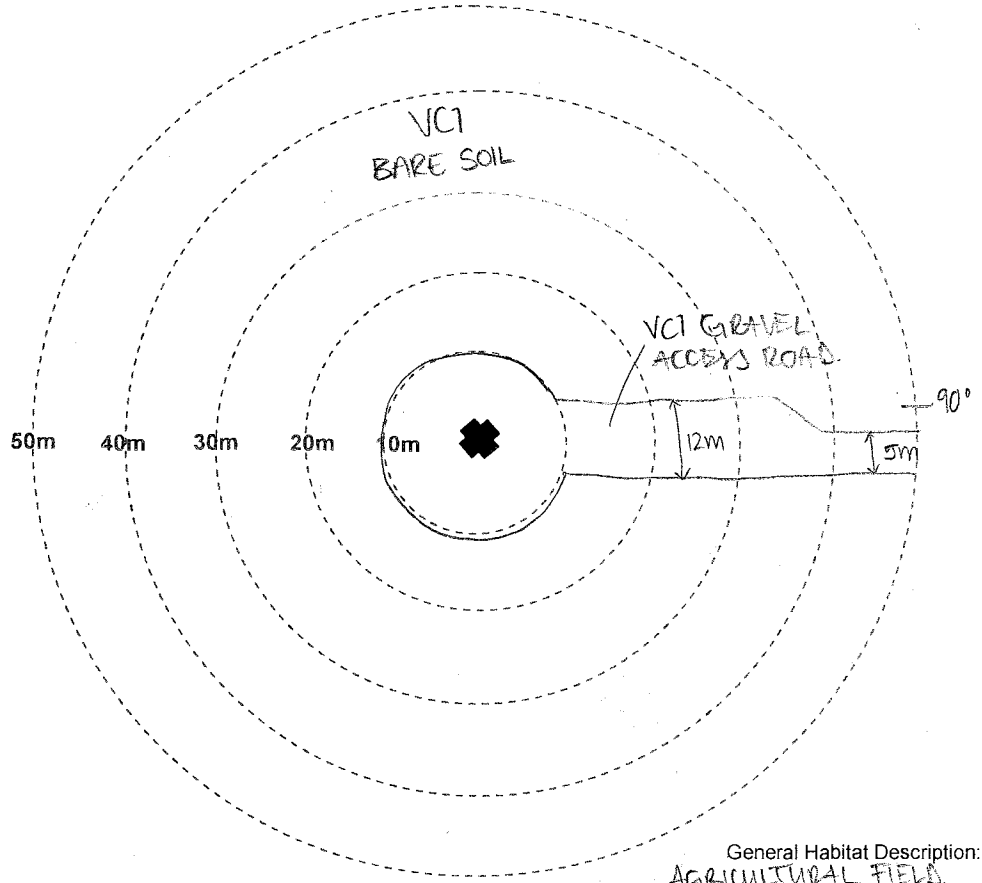


Photo Numbers (from turbine base)
 Facing North: 11026
 Facing East: 11027
 Facing South: 11028
 Facing West: 11029
 (sketch habitat and visibility classes)

Date (DD/MM/YY): 06/08/19
 Observer: EK
 Monthly/Seasonal
 Linear Transect Width: 5-7 m



VISIBILITY CLASSES	
Class 1	≥ 90% bare ground; vegetation ≤ 15cm tall
Class 2	≥ 25% bare ground; vegetation ≤ 15cm tall
Class 3	≤ 25% bare ground; less than 25% of veg. > 30cm tall
Class 4	Little or no bare ground; more than 25% of veg. > 30cm tall
Not Searchable	Dense shrubs, woods, or other unsearchable habitats

Visibility Class Map

Project Name: GINNYS HILL VE

Project #: 18TSC Turbine #: T06

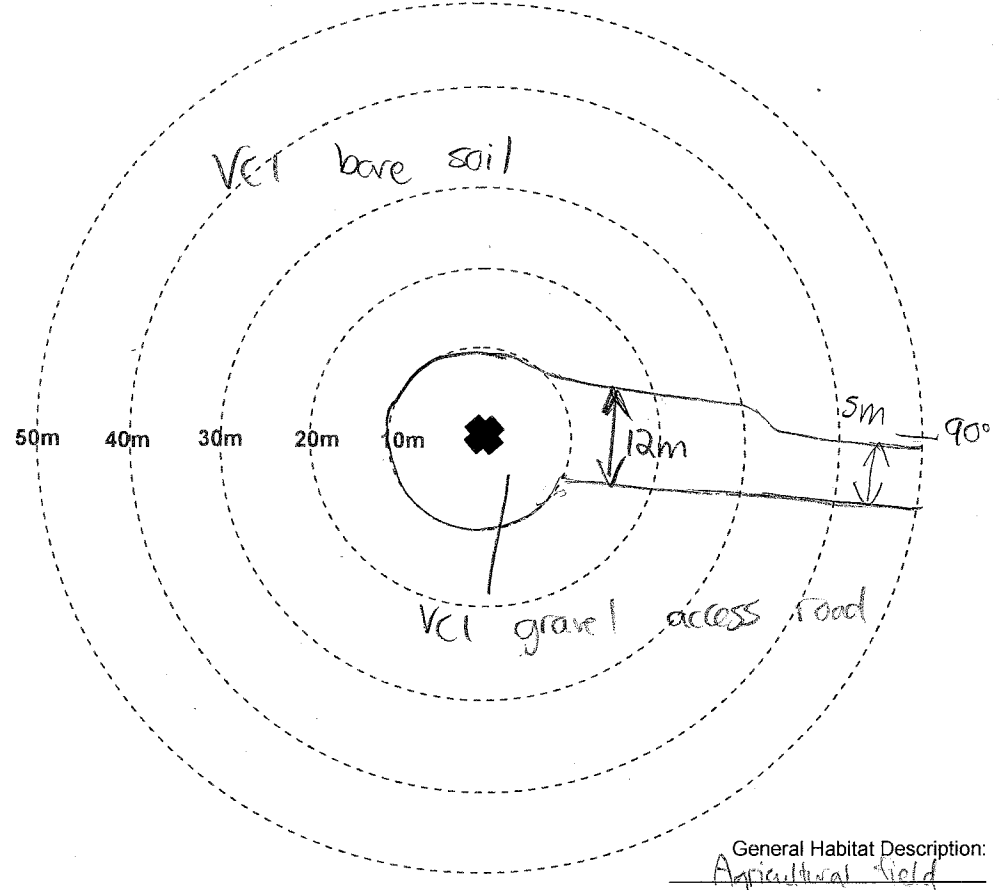
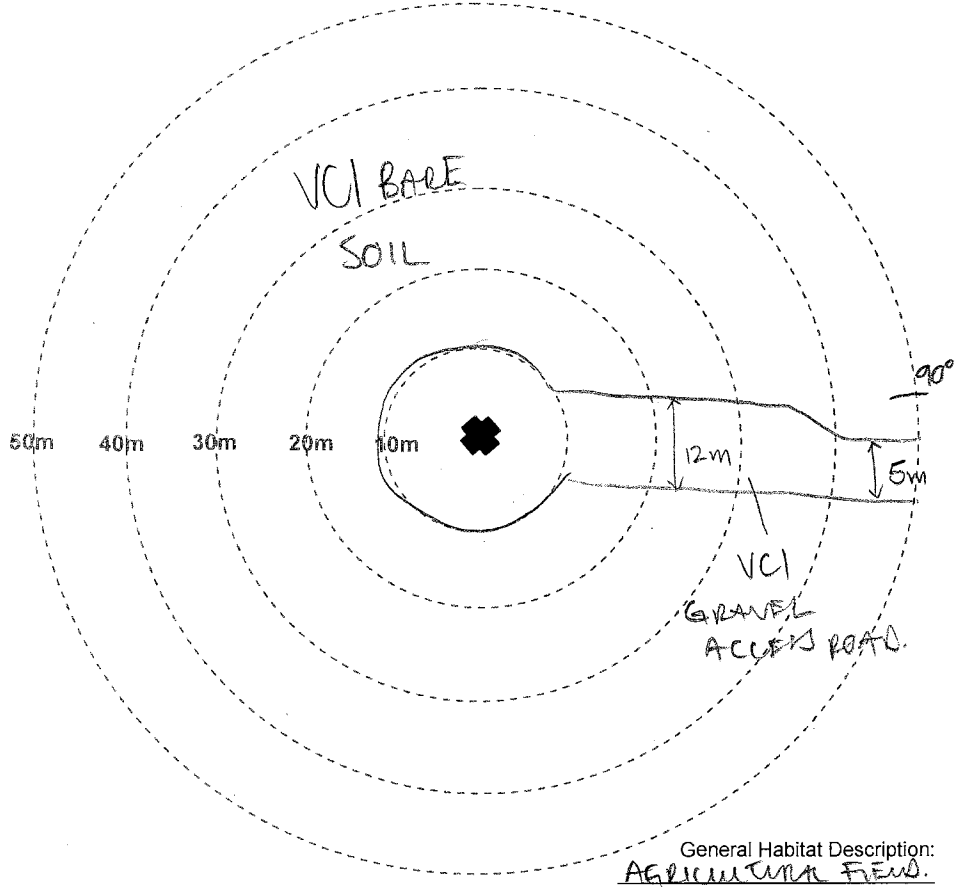
Photo Numbers (from turbine base)
 Facing North: 4234
 Facing East: 4235
 Facing South: 4236
 Facing West: 4237
 (sketch habitat and visibility classes)

Date (DD/MM/YY): 10/01/19
 Observer: EL
 Monthly/Seasonal
 Linear Transect Width: 5-7 m



Photo Numbers (from turbine base)
 Facing North: 2496
 Facing East: 2497
 Facing South: 2498
 Facing West: 2499
 (sketch habitat and visibility classes)

Date (DD/MM/YY): 08/10/19
 Observer: Taylor V
 Monthly/Seasonal
 Linear Transect Width: 5-7 m



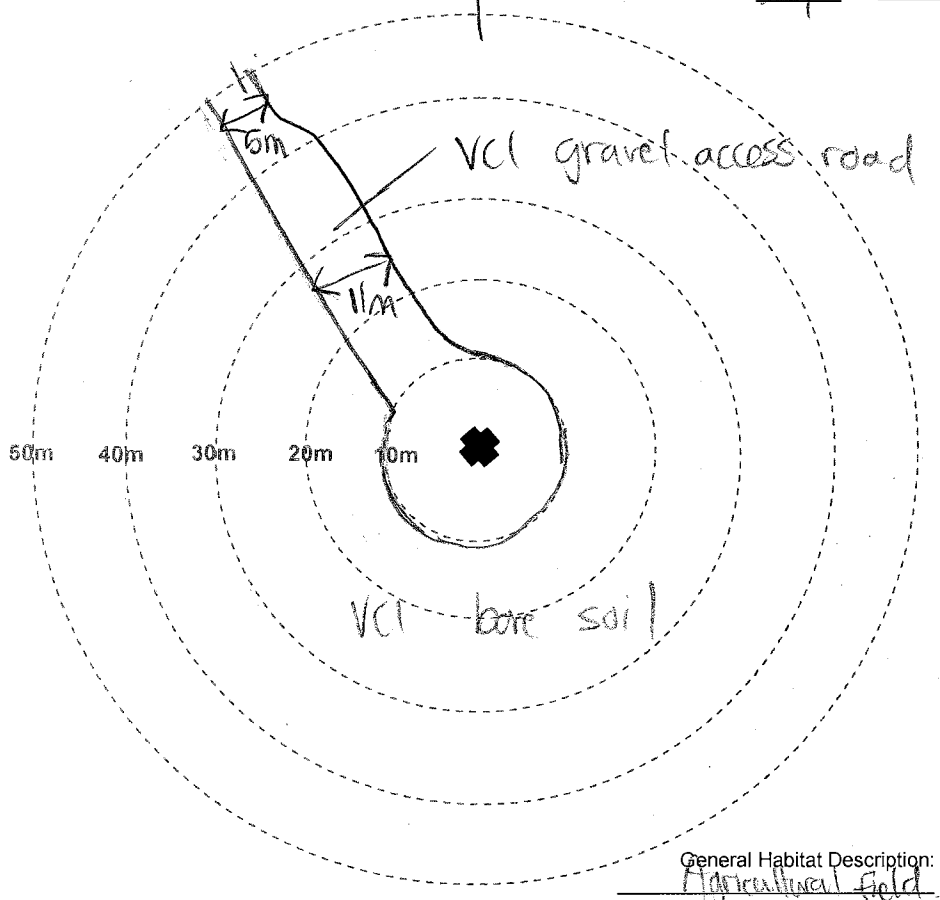
VISIBILITY CLASSES	
Class 1	≥ 90% bare ground; vegetation ≤ 15cm tall
Class 2	≥ 25% bare ground; vegetation ≤ 15cm tall
Class 3	≤ 25% bare ground; less than 25% of veg. > 30cm tall
Class 4	Little or no bare ground; more than 25% of veg. > 30cm tall
Not Searchable	Dense shrubs, woods, or other unsearchable habitats

Visibility Class Map

Project Name: Gunn's Hill WF Project #: 1875C Turbine #: T07 Degree of Slope 2 degrees Slope Orientation SW (e.g. SSW)

Photo Numbers (from turbine base)
 Facing North: 1792
 Facing East: 1793
 Facing South: 1794
 Facing West: 1795
 (sketch habitat and visibility classes)

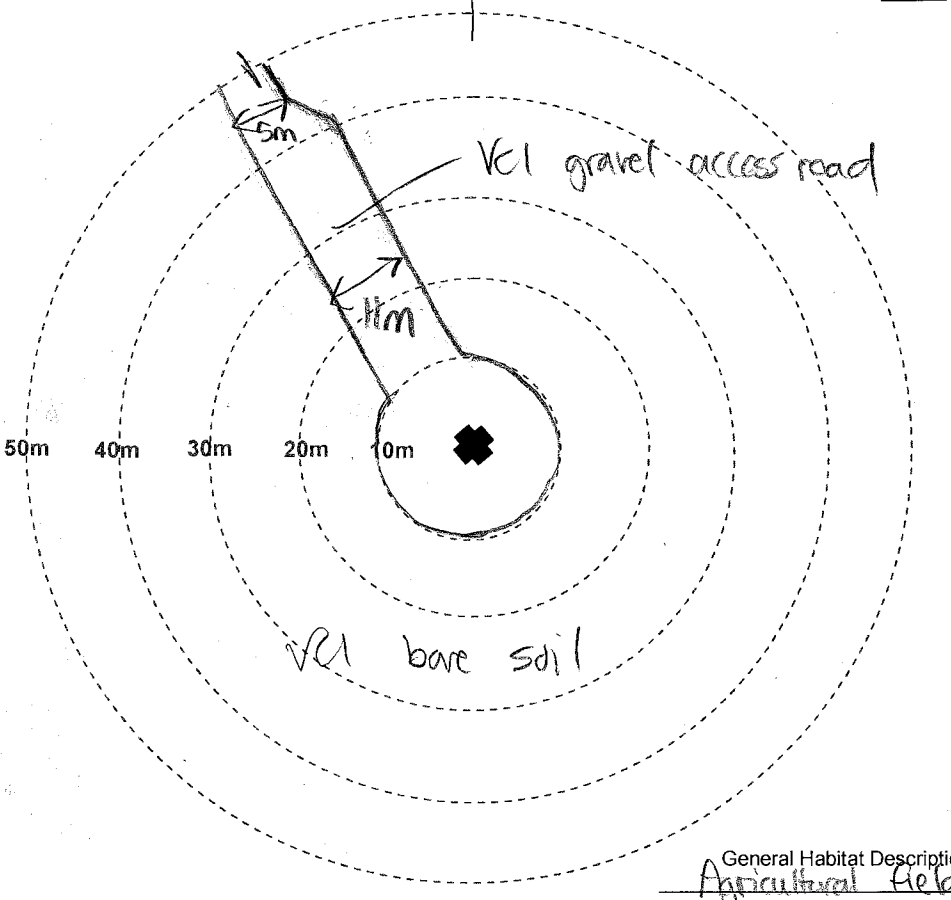
Date (DD/MM/YY): 07/05/19
 Observer: Taylor V
 Monthly/Seasonal
 Linear Transect Width: 5-7 m



General Habitat Description:
Agricultural field

Photo Numbers (from turbine base)
 Facing North: 2023
 Facing East: 2024
 Facing South: 2025
 Facing West: 2026
 (sketch habitat and visibility classes)

Date (DD/MM/YY): 07/06/19
 Observer: Taylor V
 Monthly/Seasonal
 Linear Transect Width: 5-7 m



General Habitat Description:
Agricultural field

VISIBILITY CLASSES	
Class 1	≥ 90% bare ground; vegetation ≤ 15cm tall
Class 2	≥ 25% bare ground; vegetation ≤ 15cm tall
Class 3	≤ 25% bare ground; less than 25% of veg. > 30cm tall
Class 4	Little or no bare ground; more than 25% of veg. > 30cm tall
Not Searchable	Dense shrubs, woods, or other unsearchable habitats

Visibility Class Map

Project Name: GUNN'S HILL WFE Project #: 1815C Turbine #: T07

Photo Numbers (from turbine base)
 Facing North: V018
 Facing East: V019
 Facing South: V020
 Facing West: V021
 (sketch habitat and visibility classes)

Date (DD/MM/YY): 09 / 07 / 19
 Observer: EX
 Monthly/Seasonal
 Linear Transect Width: 5-7 m

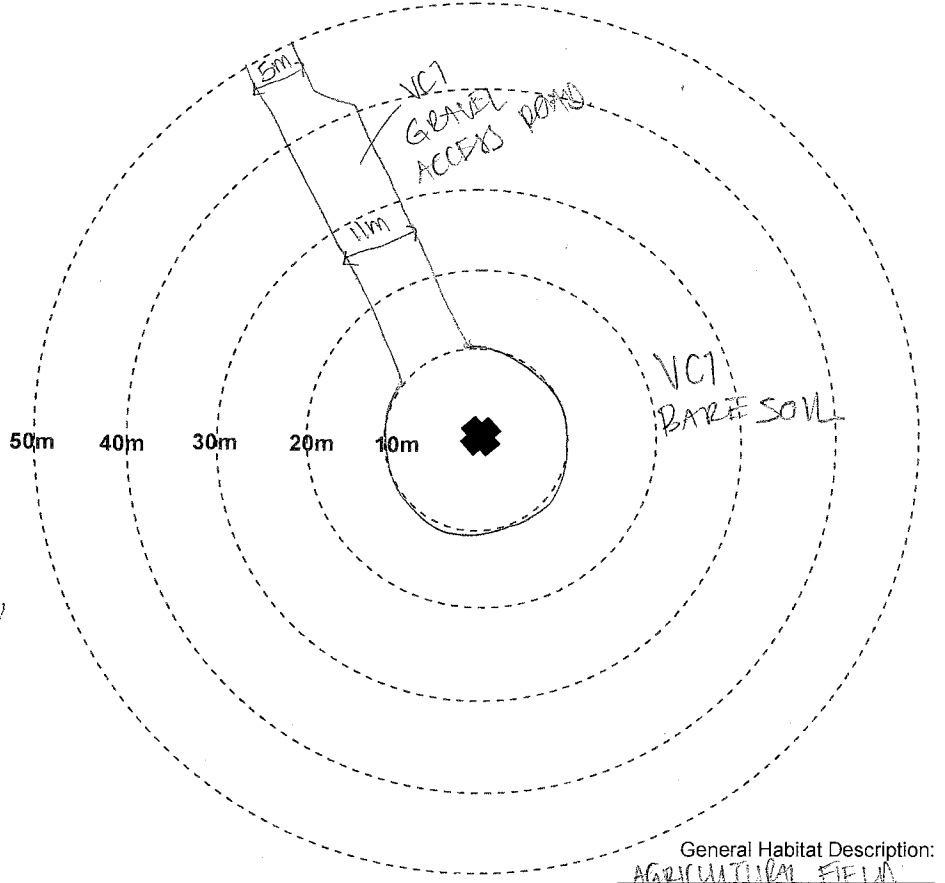
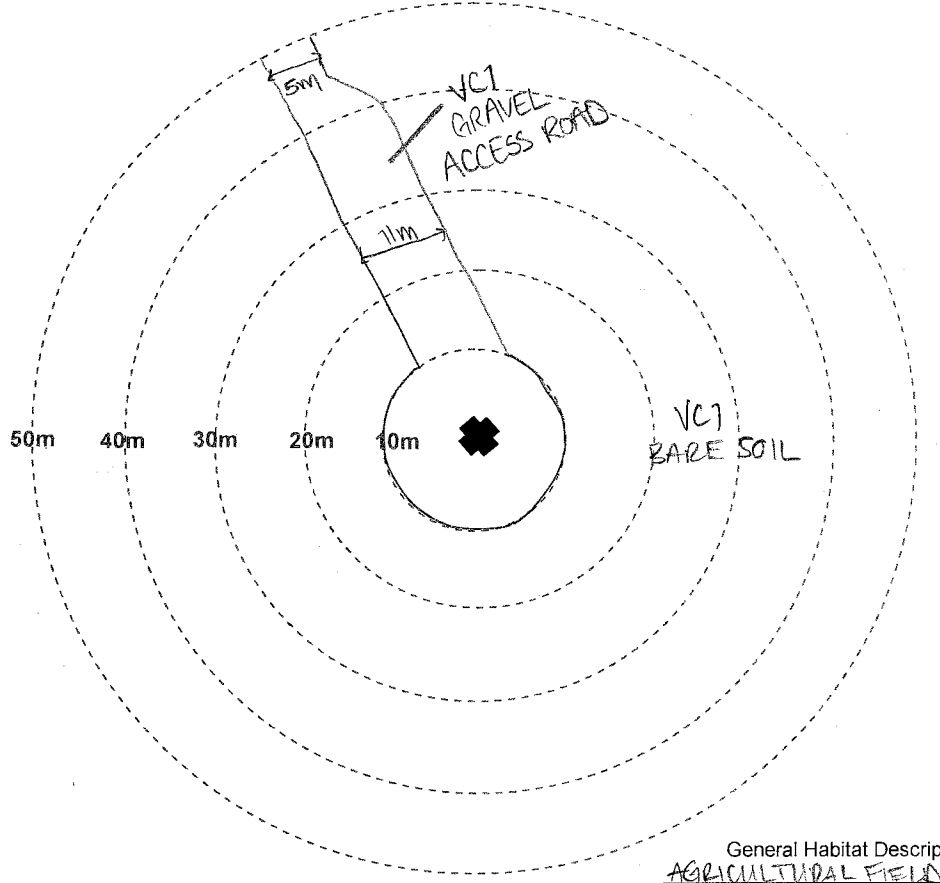


Photo Numbers (from turbine base)
 Facing North: V110
 Facing East: V111
 Facing South: V112
 Facing West: V113
 (sketch habitat and visibility classes)

Date (DD/MM/YY): 06 / 08 / 19
 Observer: EX
 Monthly/Seasonal
 Linear Transect Width: 5-7 m



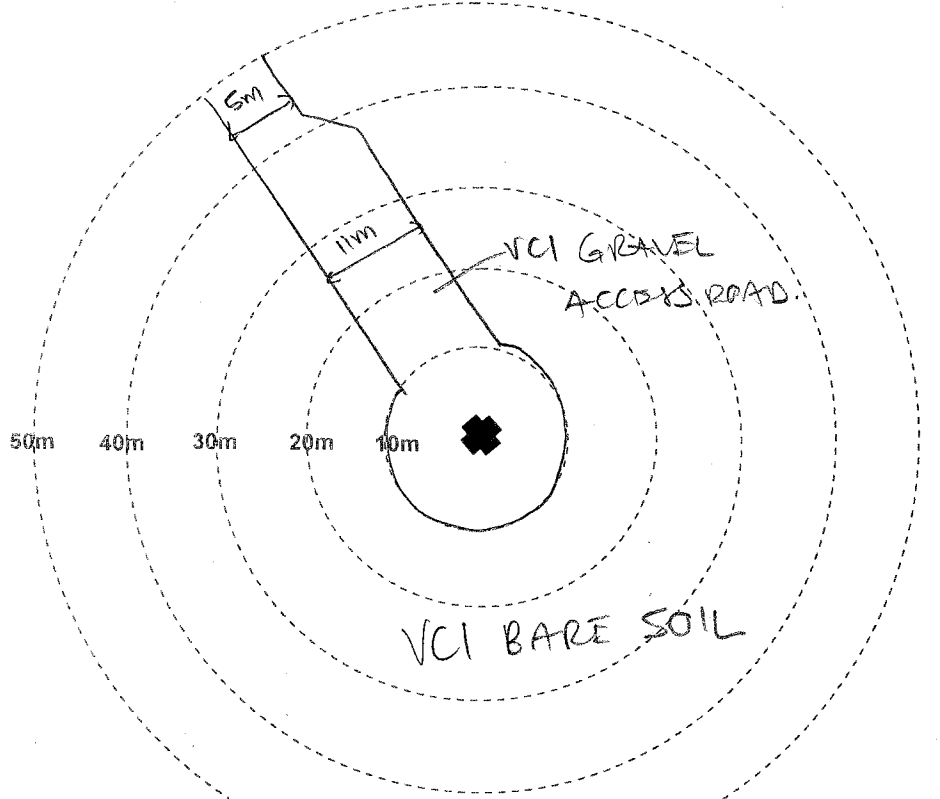
VISIBILITY CLASSES	
Class 1	≥ 90% bare ground; vegetation ≤ 15cm tall
Class 2	≥ 25% bare ground; vegetation ≤ 15cm tall
Class 3	≤ 25% bare ground; less than 25% of veg. > 30cm tall
Class 4	Little or no bare ground; more than 25% of veg. > 30cm tall
Not Searchable	Dense shrubs, woods, or other unsearchable habitats

Visibility Class Map

Project Name: GUNN'S HILL WF. Project #: 18756 Turbine #: T07

Photo Numbers (from turbine base)
 Facing North: 4239
 Facing East: 4240
 Facing South: 4241
 Facing West: 4242
 (sketch habitat and visibility classes)

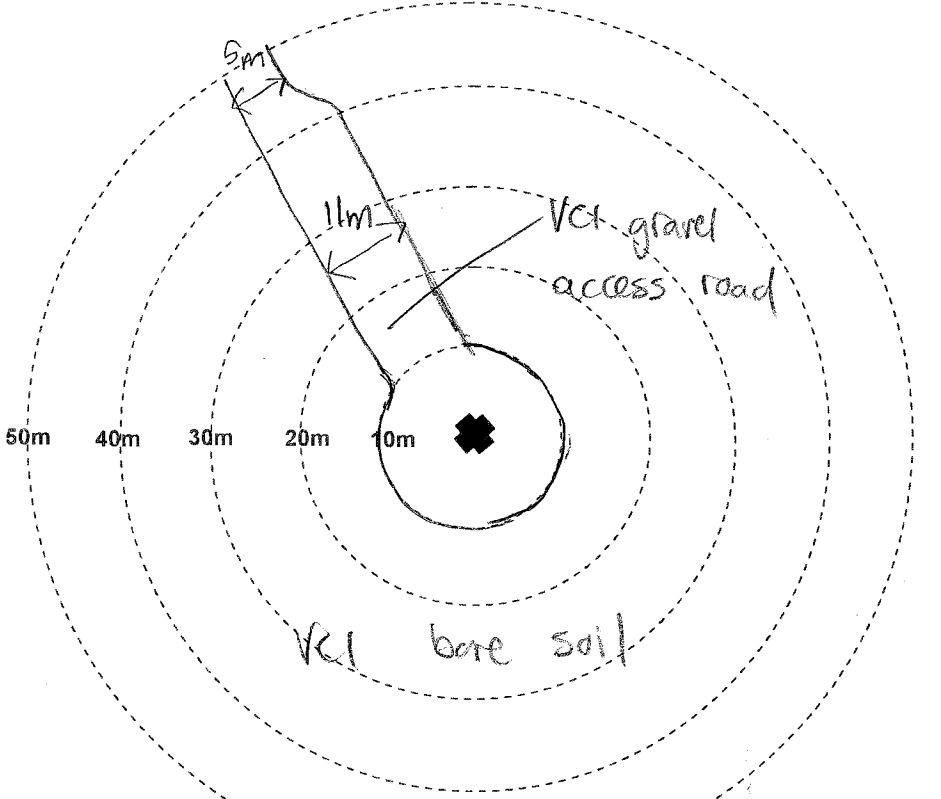
Date (DD/MM/YY): 10 / 09 / 19
 Observer: E.K.
 Monthly/Seasonal
 Linear Transect Width: 5-7 m



General Habitat Description:
AGRICULTURAL FIELD.

Photo Numbers (from turbine base)
 Facing North: 2443
 Facing East: 2444
 Facing South: 2445
 Facing West: 2446
 (sketch habitat and visibility classes)

Date (DD/MM/YY): 09 / 10 / 19
 Observer: Taylor V
 Monthly/Seasonal
 Linear Transect Width: 5-7 m



General Habitat Description:
Agricultural Field

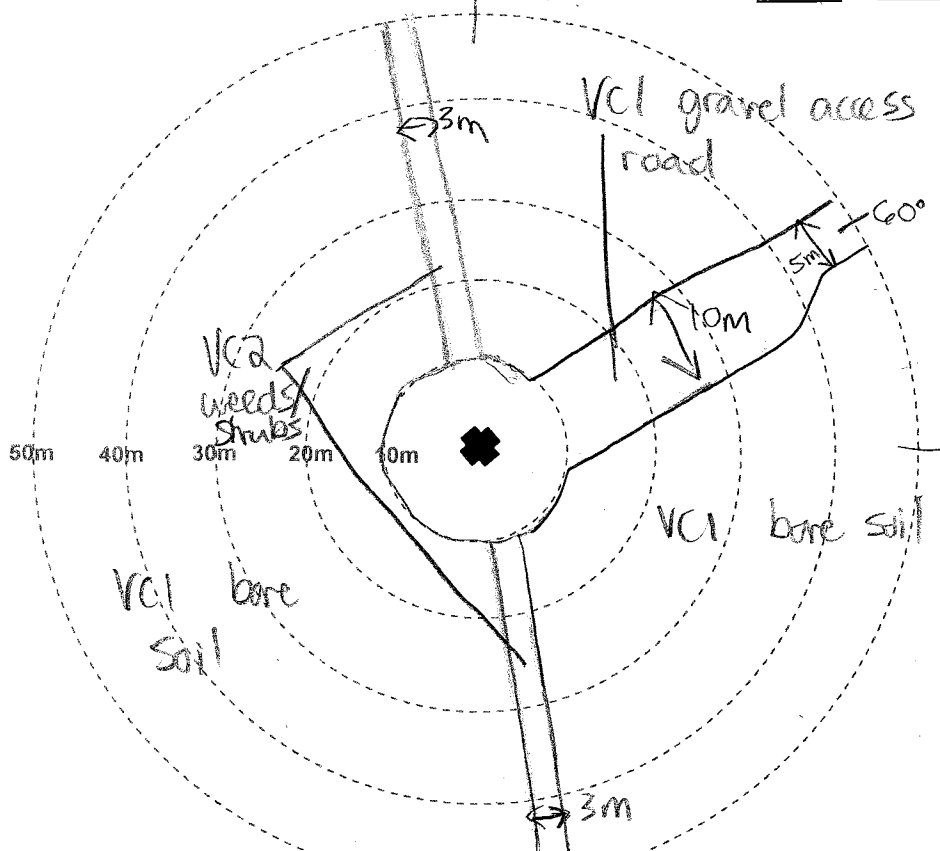
VISIBILITY CLASSES	
Class 1	≥ 90% bare ground; vegetation ≤ 15cm tall
Class 2	≥ 25% bare ground; vegetation ≤ 15cm tall
Class 3	≤ 25% bare ground; less than 25% of veg. > 30cm tall
Class 4	Little or no bare ground; more than 25% of veg. > 30cm tall
Not Searchable	Dense shrubs, woods, or other unsearchable habitats

Visibility Class Map

Project Name: Gunn's Hill WF Project #: 1875C Turbine #: T08 Degree of Slope 4 degrees Slope Orientation S (e.g. SSW)

Photo Numbers (from turbine base)
 Facing North: 1802
 Facing East: 1803
 Facing South: 1804
 Facing West: 1805
 (sketch habitat and visibility classes)

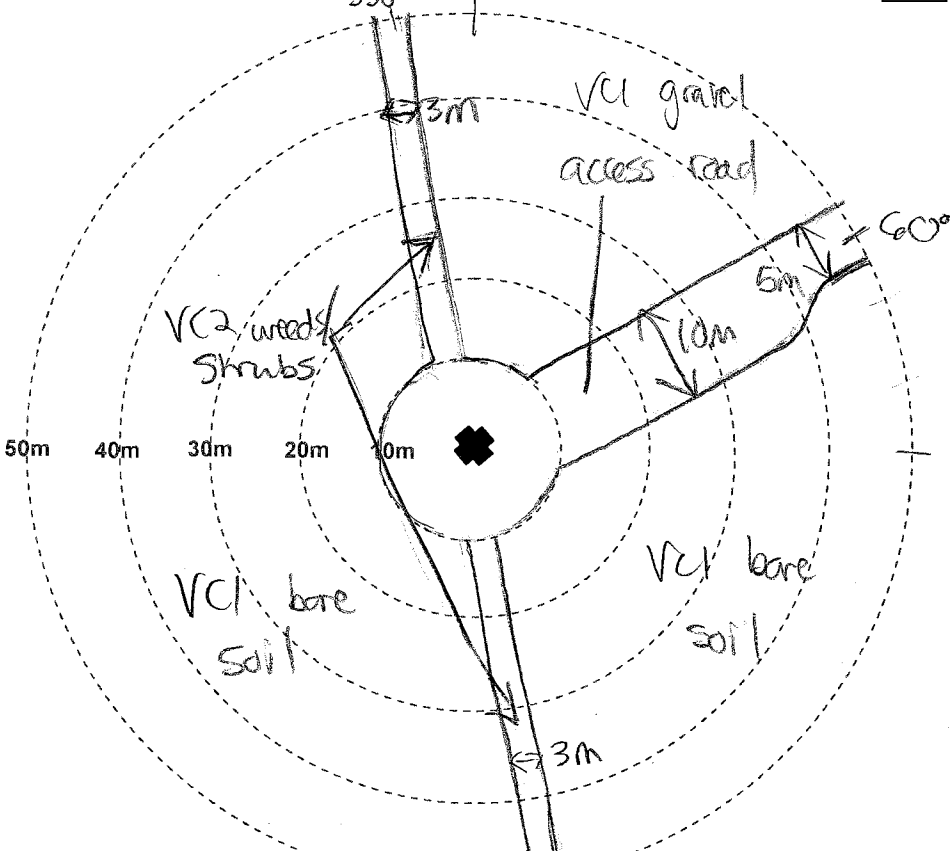
Date (DD/MM/YY): 07/05/19
 Observer: Taylor V
 Monthly/Seasonal
 Linear Transect Width: 5-7 m



General Habitat Description:
Agricultural field

Photo Numbers (from turbine base)
 Facing North: 1951
 Facing East: 1955
 Facing South: 1956
 Facing West: 1957
 (sketch habitat and visibility classes)

Date (DD/MM/YY): 04/06/19
 Observer: Taylor V
 Monthly/Seasonal
 Linear Transect Width: 5-7 m



General Habitat Description:
Agricultural field

VISIBILITY CLASSES	
Class 1	≥ 90% bare ground; vegetation ≤ 15cm tall
Class 2	≥ 25% bare ground; vegetation ≤ 15cm tall
Class 3	≤ 25% bare ground; less than 25% of veg. > 30cm tall
Class 4	Little or no bare ground; more than 25% of veg. > 30cm tall
Not Searchable	Dense shrubs, woods, or other unsearchable habitats

Visibility Class Map

Project Name: CUNNING'S HILL WAF

Project #: 18750 Turbine #: T08

Photo Numbers (from turbine base)

Facing North: U031
 Facing East: U032
 Facing South: U033
 Facing West: U034

(sketch habitat and visibility classes)

Date (DD/MM/YY): 09/07/19

Observer: EV

Monthly/Seasonal
 Linear Transect Width: 5-7 m



Photo Numbers (from turbine base)

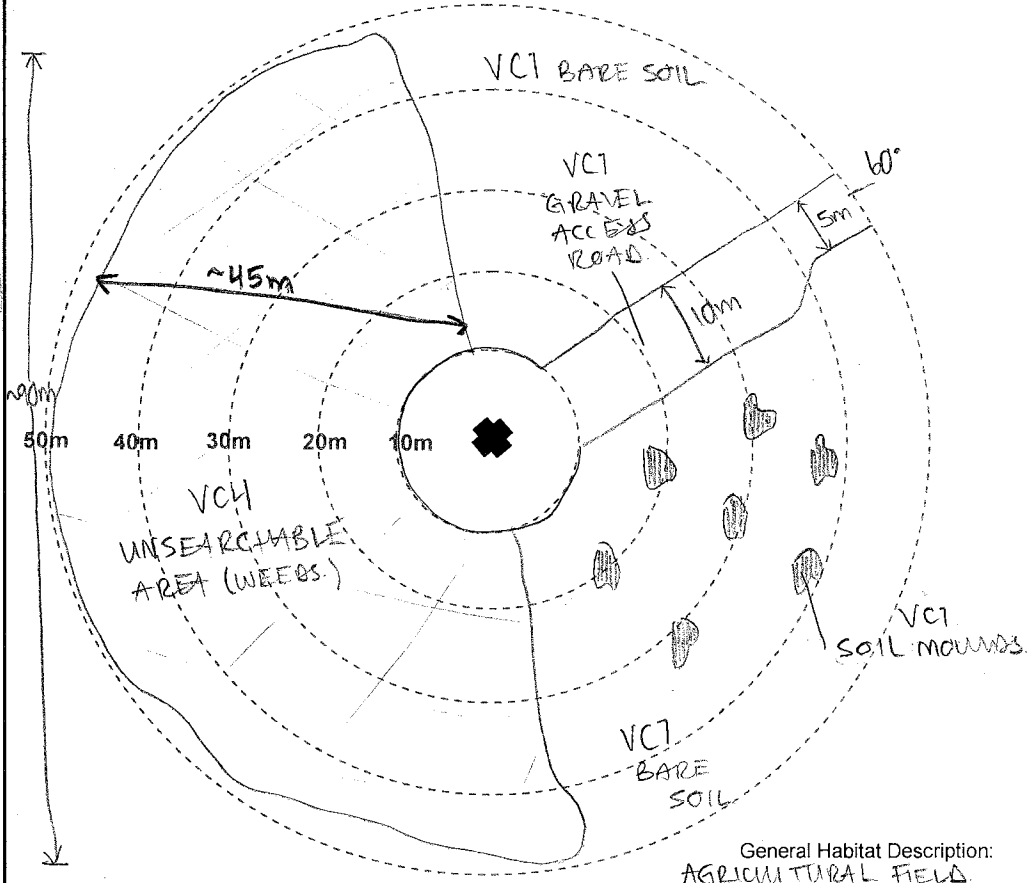
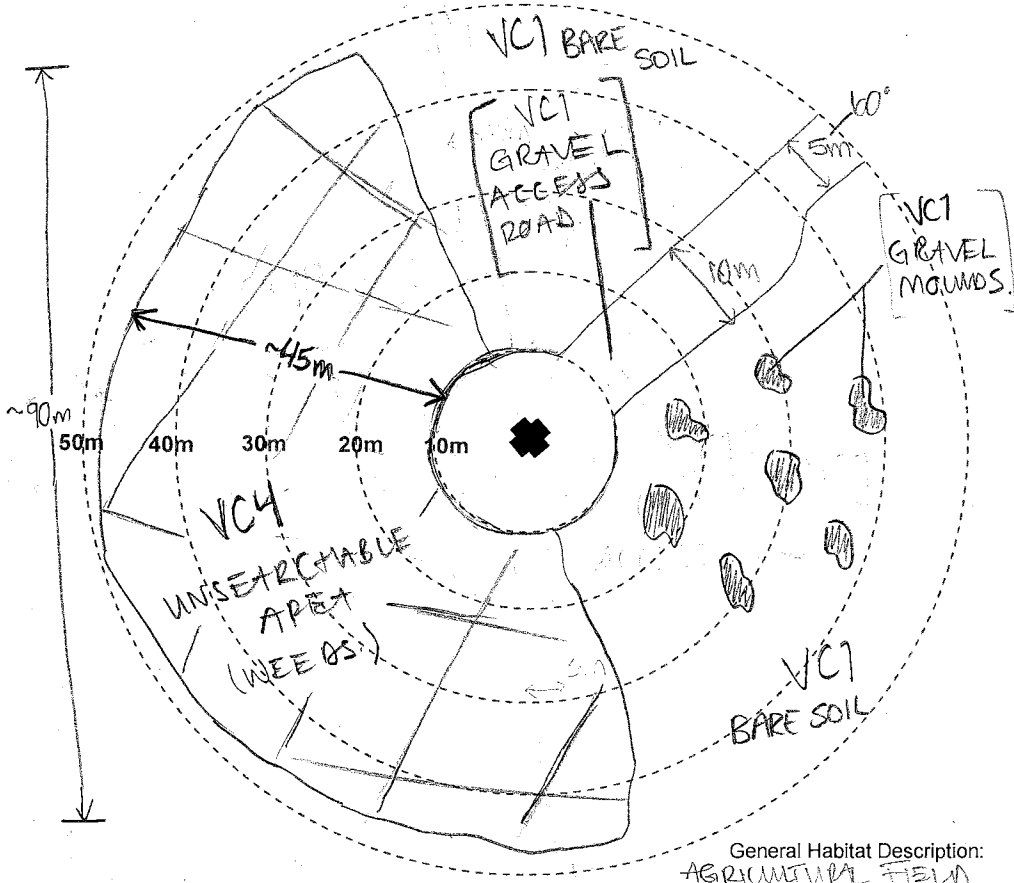
Facing North: U114
 Facing East: U115
 Facing South: U116
 Facing West: U117

(sketch habitat and visibility classes)

Date (DD/MM/YY): 06/08/19

Observer: EV

Monthly/Seasonal
 Linear Transect Width: 5-7 m



VISIBILITY CLASSES	
Class 1	≥ 90% bare ground; vegetation ≤ 15cm tall
Class 2	≥ 25% bare ground; vegetation ≤ 15cm tall
Class 3	≤ 25% bare ground; less than 25% of veg. > 30cm tall
Class 4	Little or no bare ground; more than 25% of veg. > 30cm tall
Not Searchable	Dense shrubs, woods, or other unsearchable habitats

Visibility Class Map

Project Name: GIANN'S HILL WFE

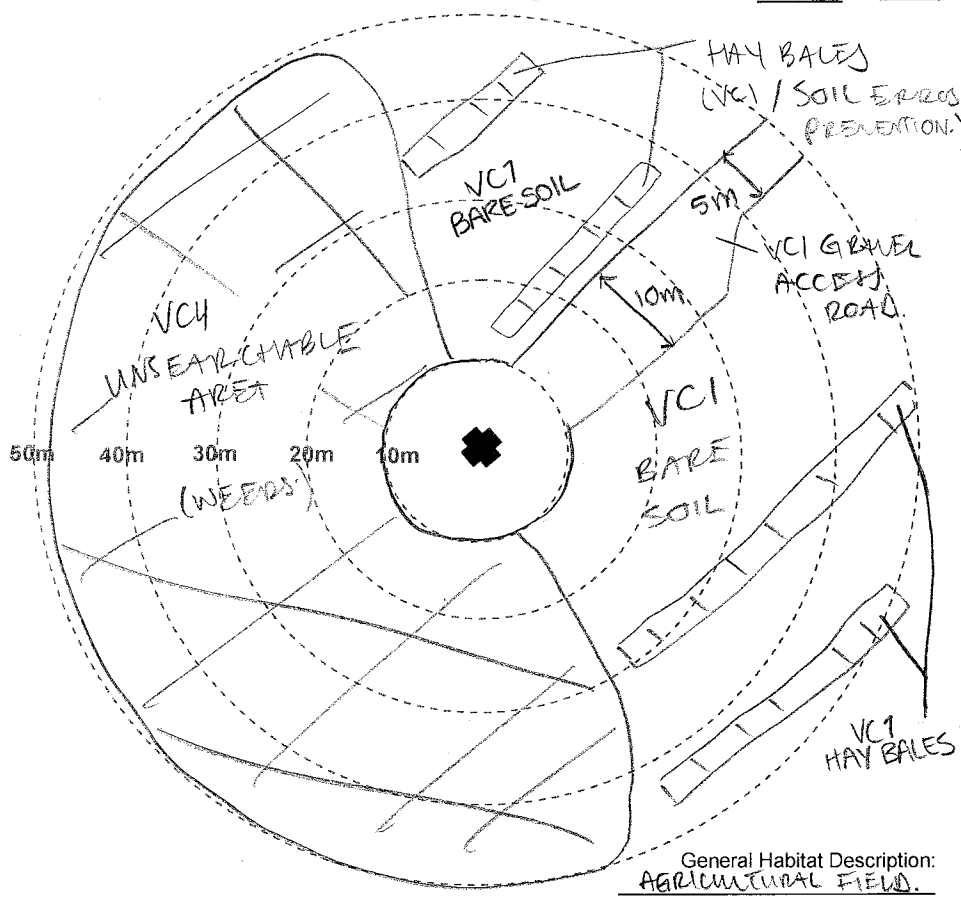
Project #: 18756 Turbine #: 108

Photo Numbers (from turbine base)
 Facing North: 11243
 Facing East: 11244
 Facing South: 11245
 Facing West: 11246
 (sketch habitat and visibility classes)

Date (DD/MM/YY): 10 / 09 / 19

Observer: EK

Monthly/Seasonal
 Linear Transect Width: 5-7 m



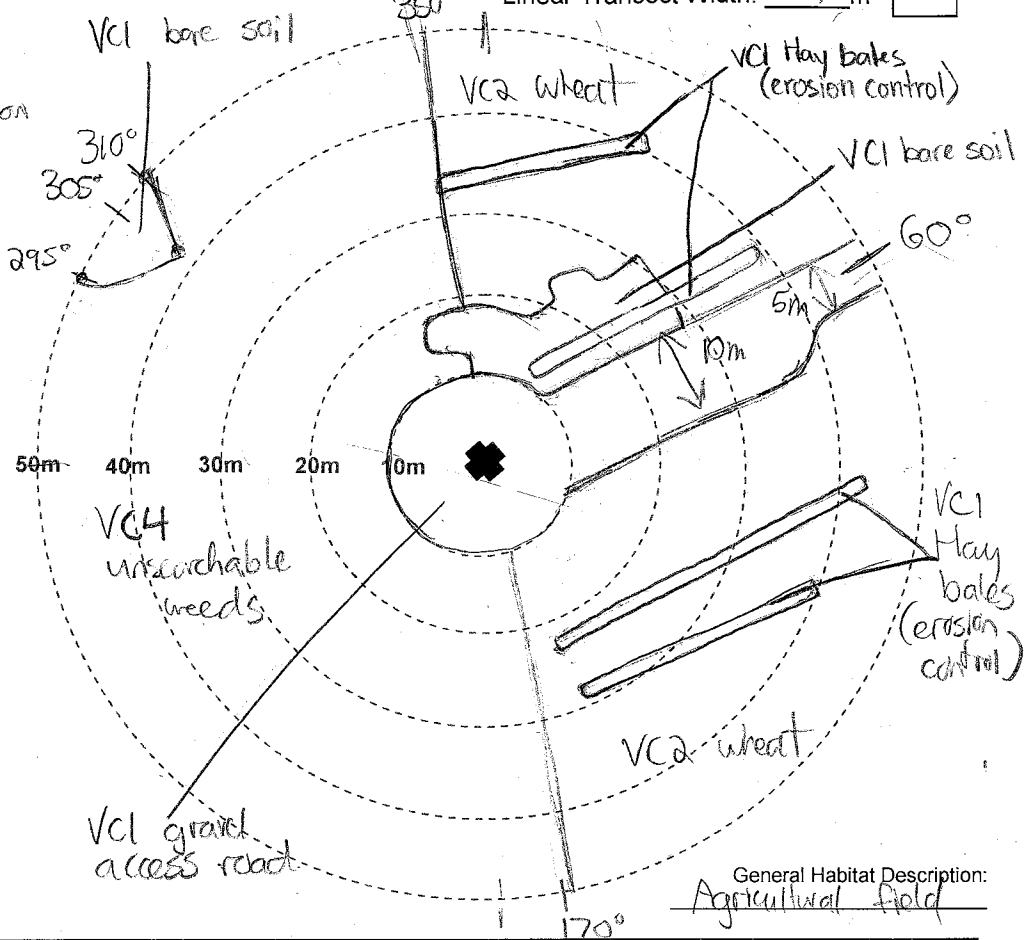
General Habitat Description:
AGRICULTURAL FIELD.

Photo Numbers (from turbine base)
 Facing North: 2457
 Facing East: 2458
 Facing South: 2459
 Facing West: 2460
 (sketch habitat and visibility classes)

Date (DD/MM/YY): 04 / 10 / 19

Observer: Taylor V

Monthly/Seasonal
 Linear Transect Width: 5-7 m



General Habitat Description:
Agricultural field

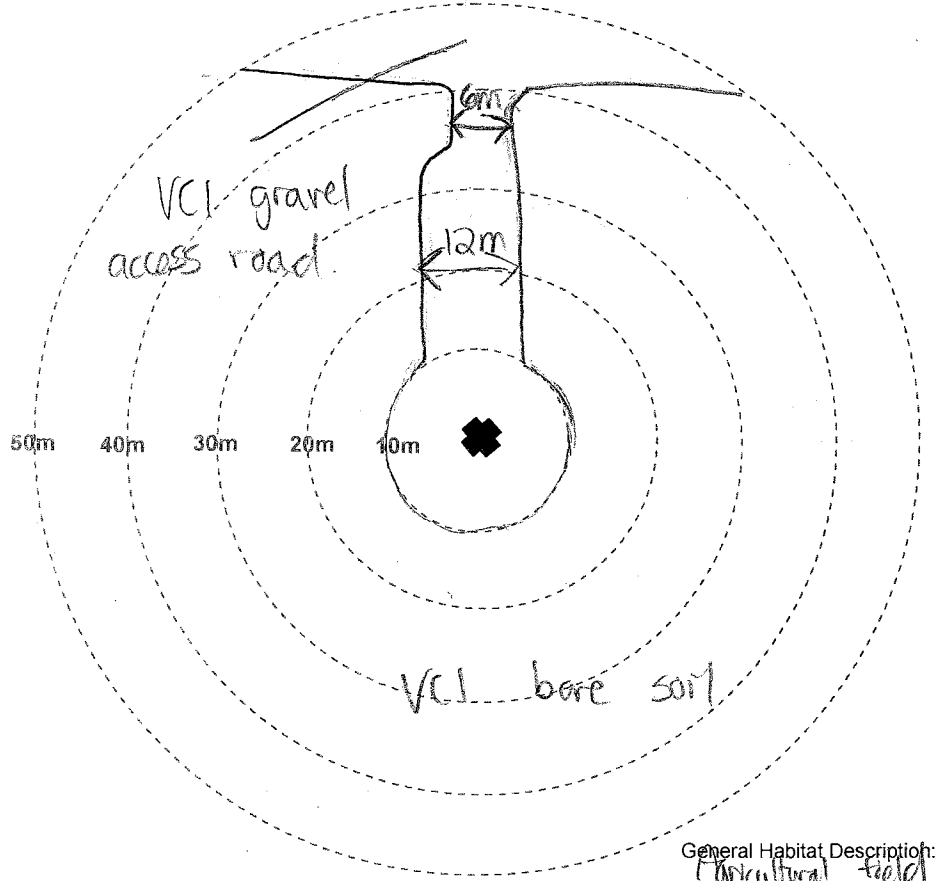
VISIBILITY CLASSES	
Class 1	≥ 90% bare ground; vegetation ≤ 15cm tall
Class 2	≥ 25% bare ground; vegetation ≤ 15cm tall
Class 3	≤ 25% bare ground; less than 25% of veg. > 30cm tall
Class 4	Little or no bare ground; more than 25% of veg. > 30cm tall
Not Searchable	Dense shrubs, woods, or other unsearchable habitats

Visibility Class Map

Project Name: Gunn's Hill WF Project #: 1875C Turbine #: T09 Degree of Slope 2 degrees Slope Orientation ESE (e.g. SSW)

Photo Numbers (from turbine base)
 Facing North: 1806
 Facing East: 1807
 Facing South: 1808
 Facing West: 1809
 (sketch habitat and visibility classes)

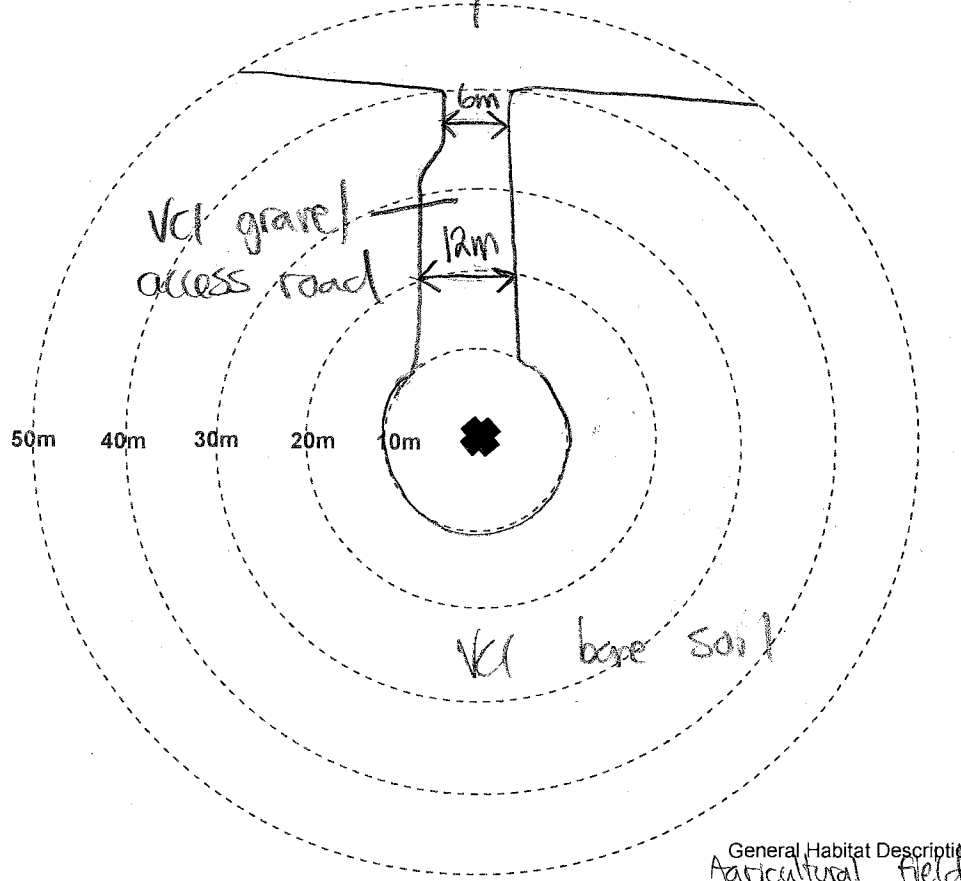
Date (DD/MM/YY): 07/05/19 ↑
 Observer: Taylor V
 Monthly/Seasonal
 Linear Transect Width: 5-7 m N



General Habitat Description:
Agricultural field

Photo Numbers (from turbine base)
 Facing North: 1998
 Facing East: 1999
 Facing South: 1900
 Facing West: 1901
 (sketch habitat and visibility classes)

Date (DD/MM/YY): 04/06/19 ↑
 Observer: Taylor V
 Monthly/Seasonal
 Linear Transect Width: 5-7 m N



General Habitat Description:
Agricultural field

VISIBILITY CLASSES	
Class 1	≥ 90% bare ground; vegetation ≤ 15cm tall
Class 2	≥ 25% bare ground; vegetation ≤ 15cm tall
Class 3	≤ 25% bare ground; less than 25% of veg. > 30cm tall
Class 4	Little or no bare ground; more than 25% of veg. > 30cm tall
Not Searchable	Dense shrubs, woods, or other unsearchable habitats

Visibility Class Map

Project Name: GUNNS HILL W.F. Project #: 1856 Turbine #: T09

Photo Numbers (from turbine base)
 Facing North: 4035
 Facing East: 4036
 Facing South: 4037
 Facing West: 4038
 (sketch habitat and visibility classes)

Date (DD/MM/YY): 09/01/19
 Observer: EX
 Monthly/Seasonal
 Linear Transect Width: 5-7 m

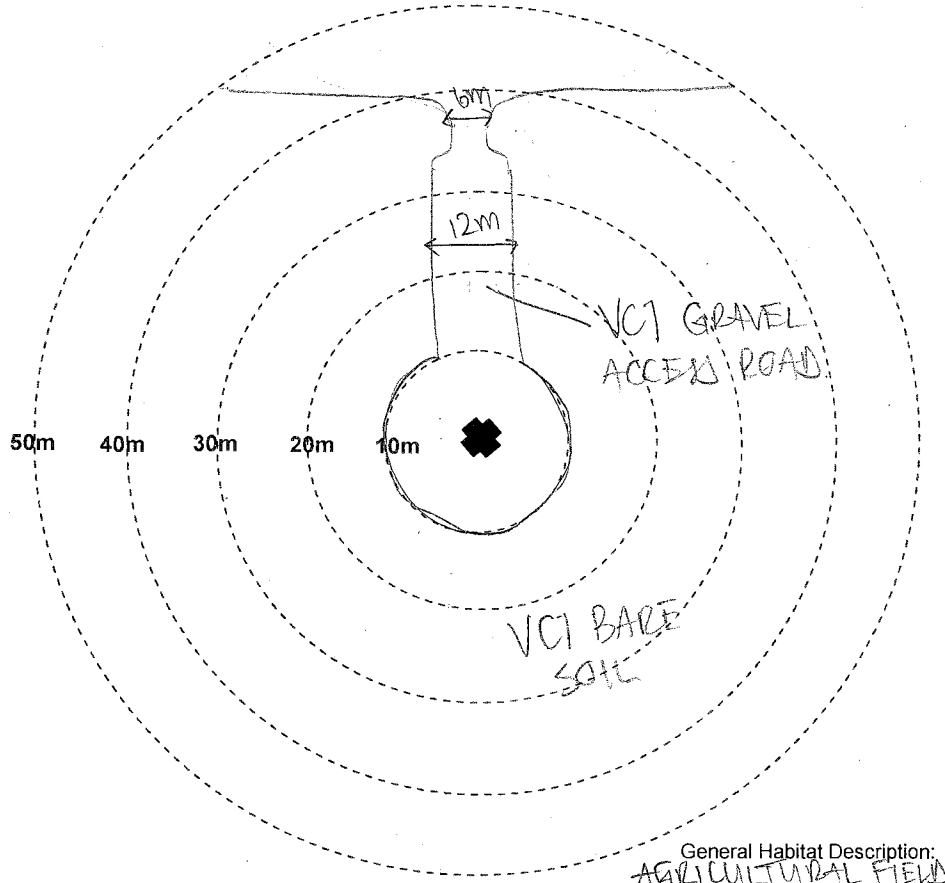
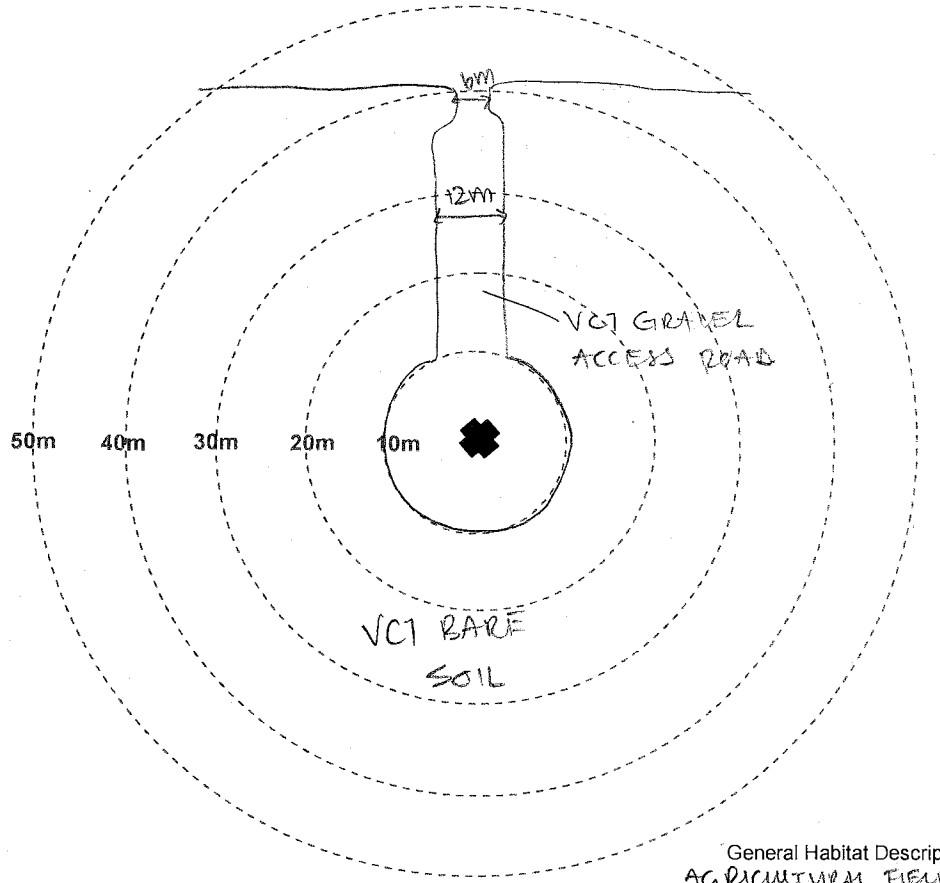


Photo Numbers (from turbine base)
 Facing North: 4146
 Facing East: 4147
 Facing South: 4148
 Facing West: 4149
 (sketch habitat and visibility classes)

Date (DD/MM/YY): 06/08/19
 Observer: EK
 Monthly/Seasonal
 Linear Transect Width: 5-7 m



VISIBILITY CLASSES	
Class 1	≥ 90% bare ground; vegetation ≤ 15cm tall
Class 2	≥ 25% bare ground; vegetation ≤ 15cm tall
Class 3	≤ 25% bare ground; less than 25% of veg. > 30cm tall
Class 4	Little or no bare ground; more than 25% of veg. > 30cm tall
Not Searchable	Dense shrubs, woods, or other unsearchable habitats

Visibility Class Map

Project Name: GUNN'S HILL WF Project #: 18756 Turbine #: TOP

Photo Numbers (from turbine base)
 Facing North: 4248
 Facing East: 4249
 Facing South: 4250
 Facing West: 4251
 (sketch habitat and visibility classes)

Date (DD/MM/YY): 10/09/19

Observer: ERIC

Monthly/Seasonal
 Linear Transect Width: 5-7 m

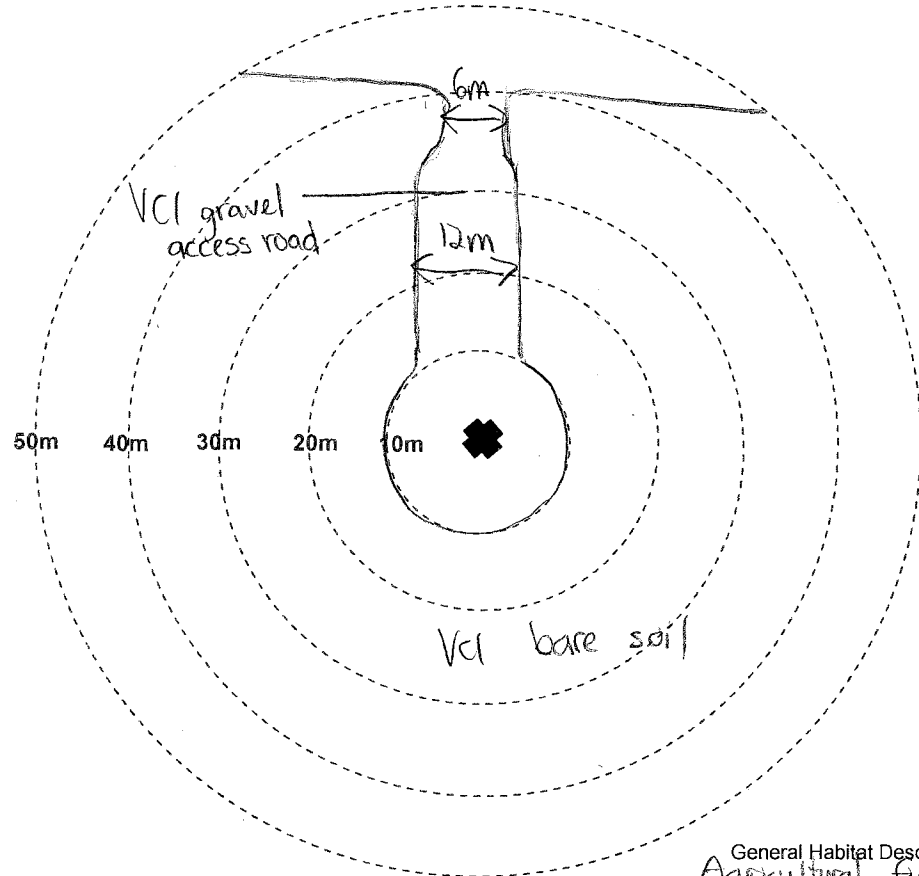
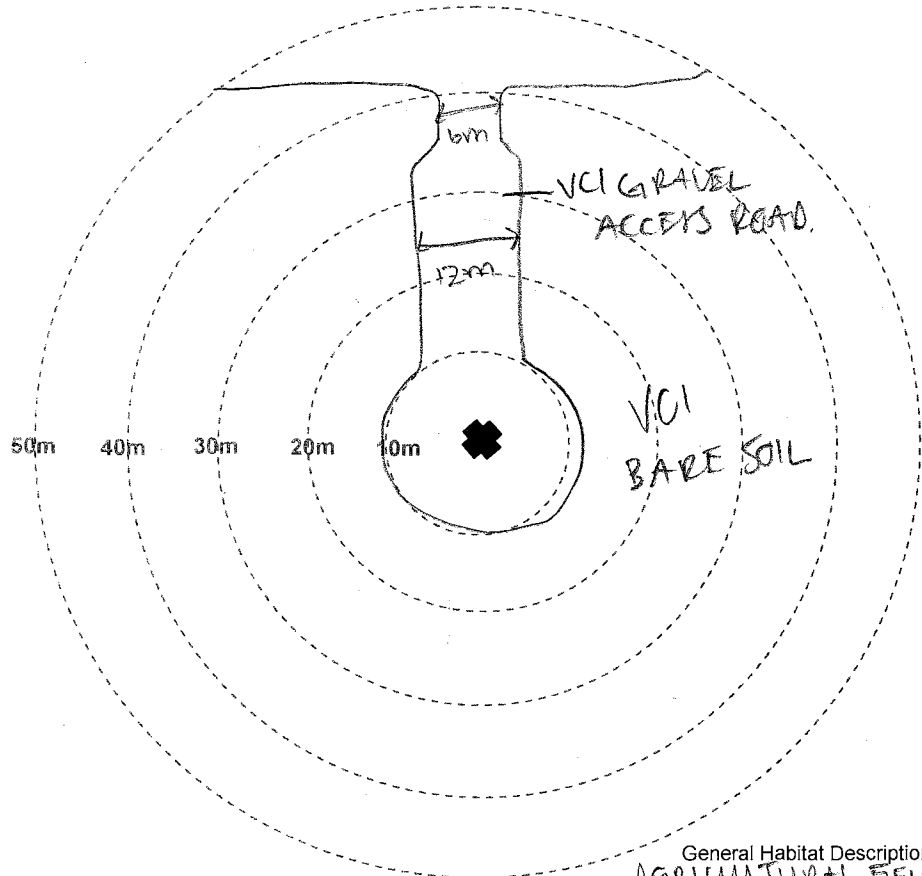


Photo Numbers (from turbine base)
 Facing North: 2504
 Facing East: 2505
 Facing South: 2506
 Facing West: 2507
 (sketch habitat and visibility classes)

Date (DD/MM/YY): 08/10/19

Observer: Taylor V

Monthly/Seasonal
 Linear Transect Width: 5-7 m



VISIBILITY CLASSES	
Class 1	≥ 90% bare ground; vegetation ≤ 15cm tall
Class 2	≥ 25% bare ground; vegetation ≤ 15cm tall
Class 3	≤ 25% bare ground; less than 25% of veg. > 30cm tall
Class 4	Little or no bare ground; more than 25% of veg. > 30cm tall
Not Searchable	Dense shrubs, woods, or other unsearchable habitats

Visibility Class Map

Project Name: Gunn's Hill WF

Project #: 1875C Turbine #: T10

Degree of Slope 0 degrees

Slope Orientation N/A (e.g. SSW)

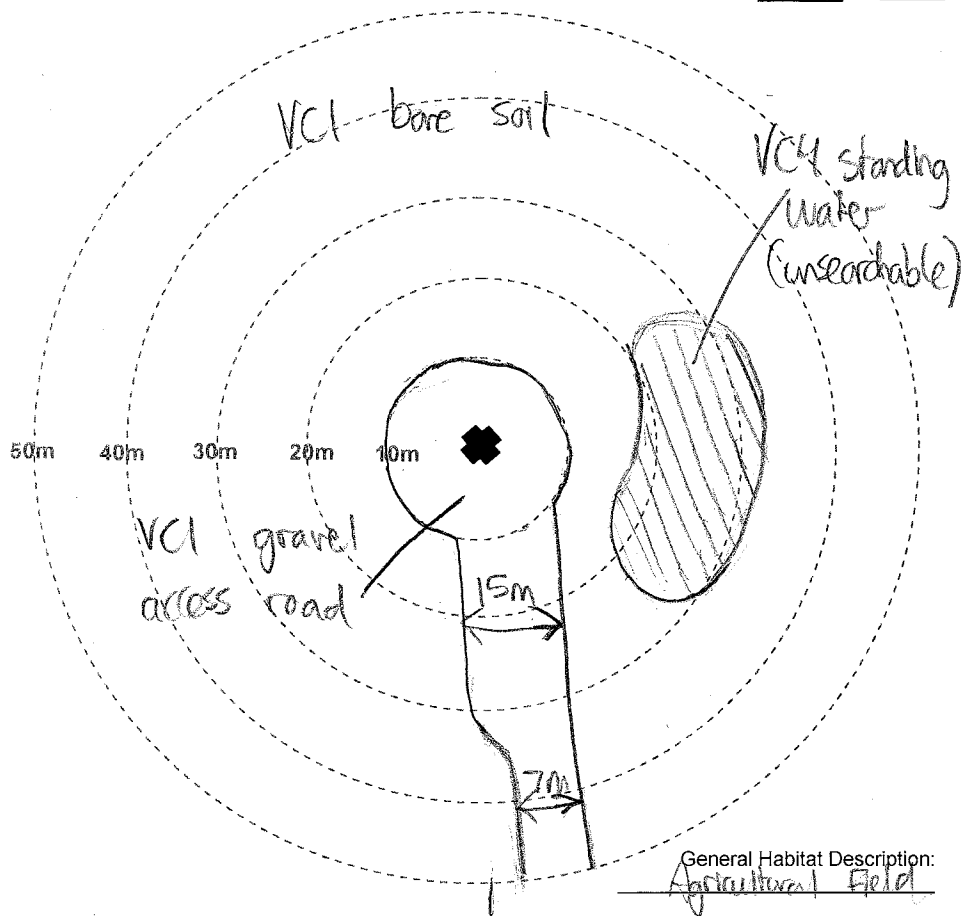
Photo Numbers (from turbine base)
 Facing North: 1811
 Facing East: 1812
 Facing South: 1813
 Facing West: 1814
 (sketch habitat and visibility classes)

Date (DD/MM/YY): 07/05/19
 Observer: Taylor V
 Monthly/Seasonal
 Linear Transect Width: 5-7 m

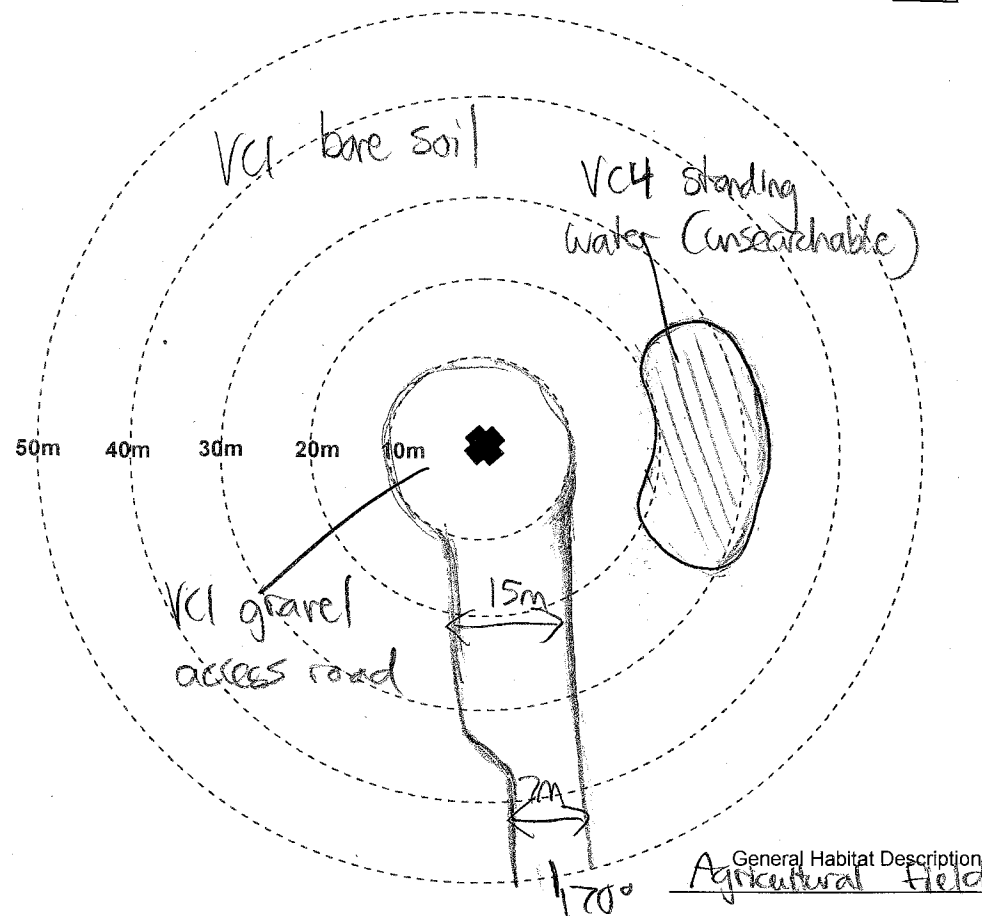


Photo Numbers (from turbine base)
 Facing North: 1962
 Facing East: 1963
 Facing South: 1964
 Facing West: 1965
 (sketch habitat and visibility classes)

Date (DD/MM/YY): 04/06/19
 Observer: Taylor V
 Monthly/Seasonal
 Linear Transect Width: 5-7 m



General Habitat Description: Agricultural Field



General Habitat Description: Agricultural Field

VISIBILITY CLASSES	
Class 1	≥ 90% bare ground; vegetation ≤ 15cm tall
Class 2	≥ 25% bare ground; vegetation ≤ 15cm tall
Class 3	≤ 25% bare ground; less than 25% of veg. > 30cm tall
Class 4	Little or no bare ground; more than 25% of veg. > 30cm tall
Not Searchable	Dense shrubs, woods, or other unsearchable habitats

Visibility Class Map

Project Name: GUNNIS HILL WF Project #: 18156 Turbine #: 70

Photo Numbers (from turbine base)
 Facing North: W039
 Facing East: W040
 Facing South: W041
 Facing West: W042
 (sketch habitat and visibility classes)

Date (DD/MM/YY): 09/01/19
 Observer: EL
 Monthly/Seasonal
 Linear Transect Width: 5-7 m

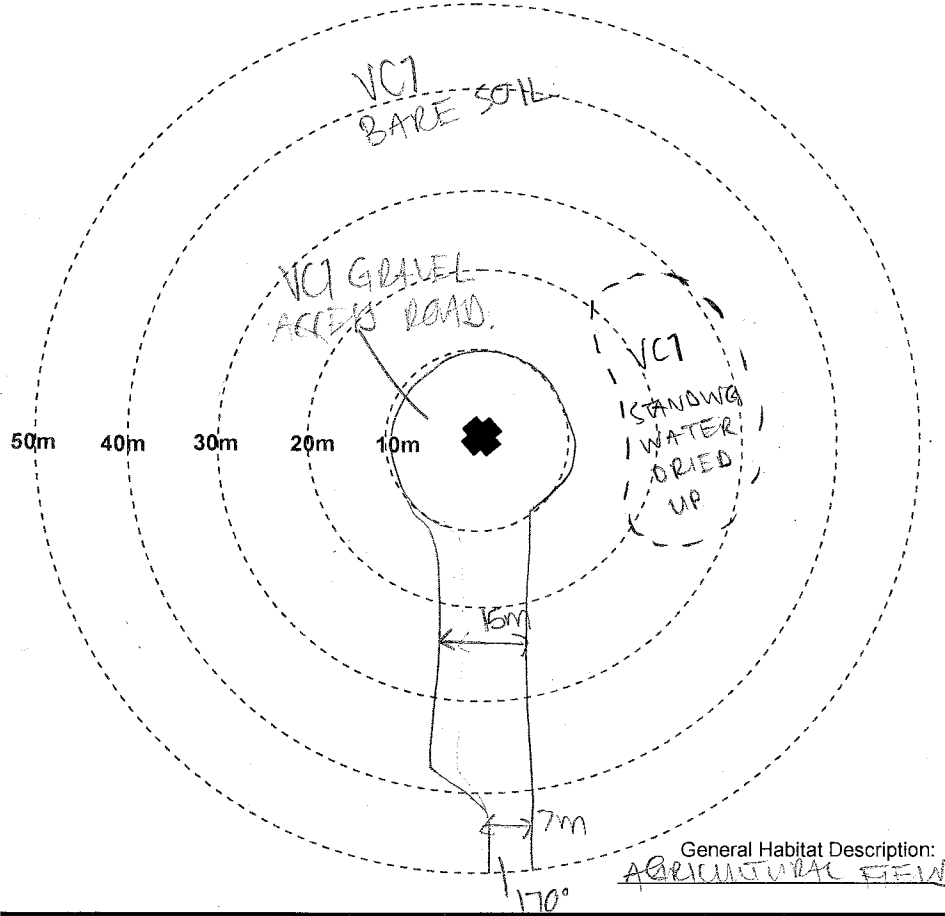
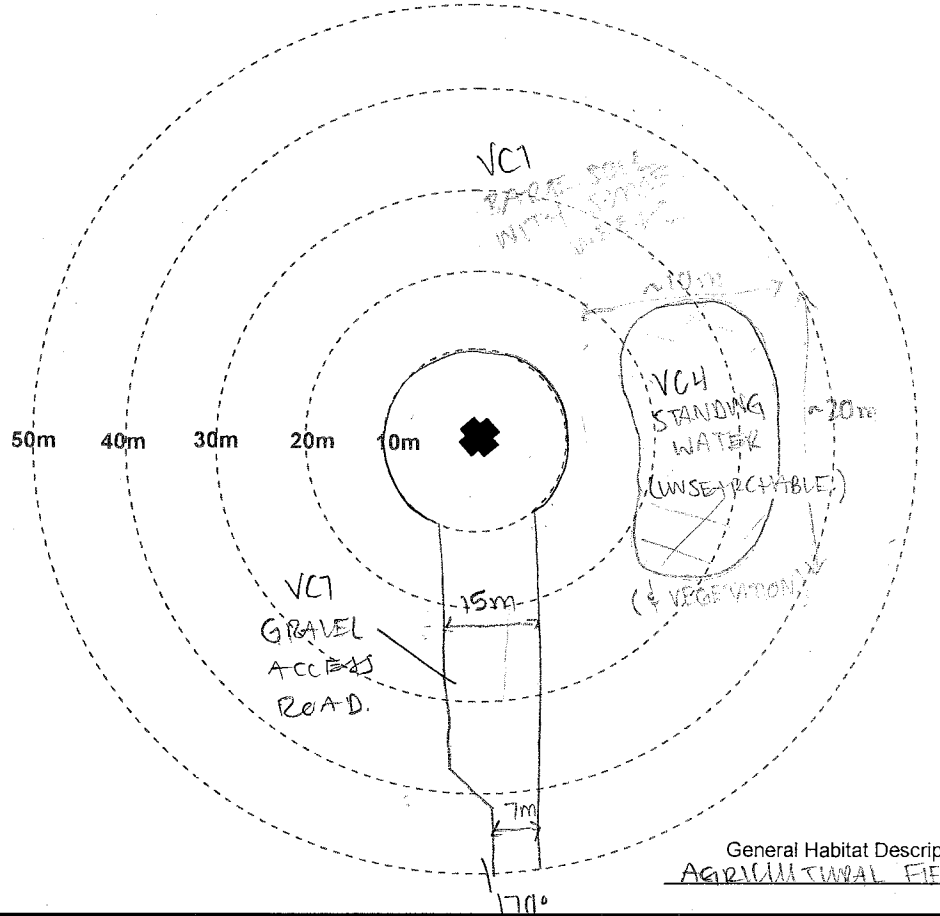


Photo Numbers (from turbine base)
 Facing North: W118
 Facing East: W119
 Facing South: W120
 Facing West: W121
 (sketch habitat and visibility classes)

Date (DD/MM/YY): 06/08/19
 Observer: EL
 Monthly/Seasonal
 Linear Transect Width: 5-7 m



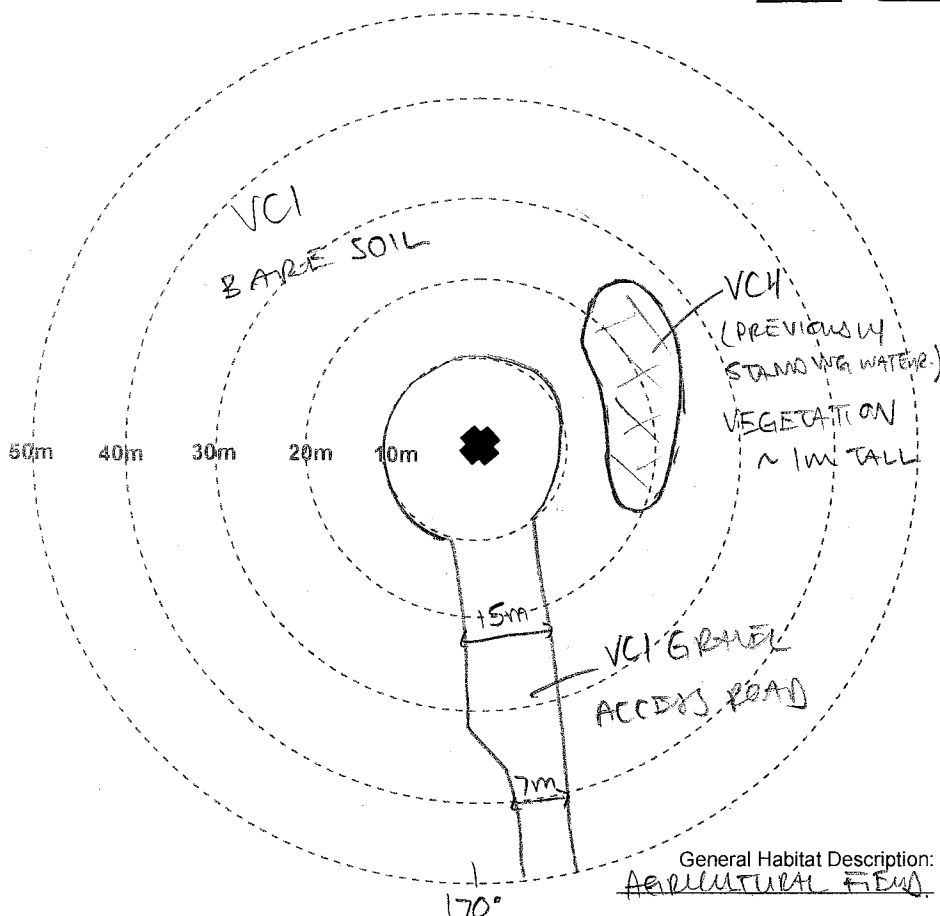
VISIBILITY CLASSES	
Class 1	≥ 90% bare ground; vegetation ≤ 15cm tall
Class 2	≥ 25% bare ground; vegetation ≤ 15cm tall
Class 3	≤ 25% bare ground; less than 25% of veg. > 30cm tall
Class 4	Little or no bare ground; more than 25% of veg. > 30cm tall
Not Searchable	Dense shrubs, woods, or other unsearchable habitats

Visibility Class Map

Project Name: SHANNON HILL W.F. Project #: 8198 Turbine #: T10

Photo Numbers (from turbine base)
 Facing North: V252
 Facing East: V253
 Facing South: V254
 Facing West: V255
 (sketch habitat and visibility classes)

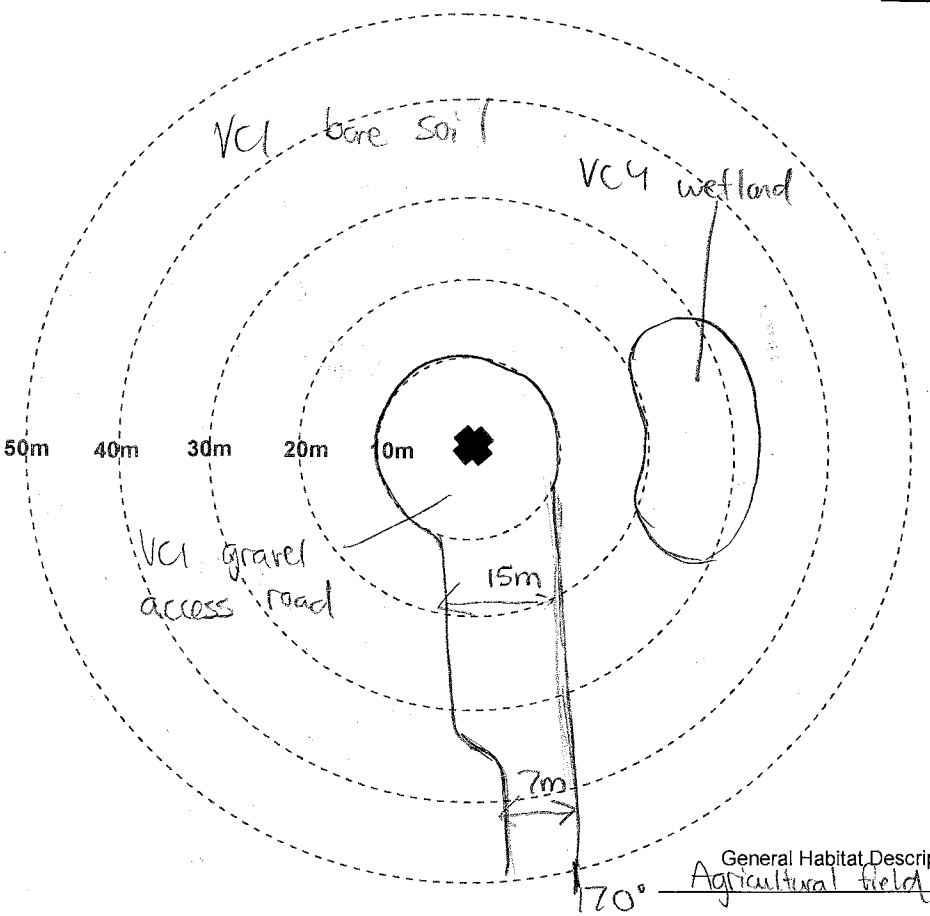
Date (DD/MM/YY): 10/09/19
 Observer: EC
 Monthly/Seasonal
 Linear Transect Width: 5-7 m



General Habitat Description: AGRICULTURAL FIELD

Photo Numbers (from turbine base)
 Facing North: 2508
 Facing East: 2509
 Facing South: 2510
 Facing West: 2511
 (sketch habitat and visibility classes)

Date (DD/MM/YY): 08/10/19
 Observer: Taylor V
 Monthly/Seasonal
 Linear Transect Width: 5-7 m



General Habitat Description: Agricultural field

VISIBILITY CLASSES	
Class 1	≥ 90% bare ground; vegetation ≤ 15cm tall
Class 2	≥ 25% bare ground; vegetation ≤ 15cm tall
Class 3	≤ 25% bare ground; less than 25% of veg. > 30cm tall
Class 4	Little or no bare ground; more than 25% of veg. > 30cm tall
Not Searchable	Dense shrubs, woods, or other unsearchable habitats